



# WALLONIA DEFENCE INDUSTRY

INNOVATION, PROJECTS & KEY PLAYERS

## Table of Contents

Cross-referenced view	05
A Strategic Sector at the Heart of Wallonia's Industry	08
Collaborative Projects	16
Walloon Defence Actors Companies	42
Walloon Defence Actors Research Centers & Universities	138
Walloon Defence Actors Key Stakeholders	156
Sectorial & Technological Matrix	168

### Cross-referenced view



Join forces to strengthen the Defence industry in Wallonia.



Hone a certain number of priority topics for Walloon actors to work on.



Promote some common projects that will structure the ecosystem.



Boost the presence of Walloon players in R&I projects, especially those funded by the European Union.



Increase the Walloon Defence sector's visibility and international recognition.



The geopolitical context reminds us that it is essential for our region to have a local and innovative Defence industry. This is the case for our subsidiary FN Herstal, which was created in the 19th century to equip the Belgian army, and today supports all European armed forces. We are world-renowned for the reliability of our products and services, and our capacity for innovation (we invest 10-15% of our sales in R&D). However, the future of our industry lies in our local ecosystem as a whole: our workers, our suppliers (over 67% of whom are Belgian companies for FN Herstal), and the educational institutions that enable us to pass on our know-how. These players, together, determine the robustness of our industry and, consequently, the strategic autonomy and security of supply of our country and its allies.

**Julien Compère**  
CEO - FN Browning Group



Sabena Engineering and SABCA are key contributors to Europe's evolving Defence landscape. With decades of experience, both companies leverage their expertise and industrial footprint to address today's operational and technological challenges. Sabena Engineering plays a critical role in ensuring fleet readiness and mission availability, supporting Defence forces in Belgium, across NATO and beyond. SABCA, with its long-standing heritage in aerostructures and advanced systems, contributes to major Defence programs and supports the development of next-generation capabilities. Strengthening Europe's Defence means reinforcing sovereignty, technological autonomy, and industrial resilience. In this context, Sabena Engineering and SABCA are committed to playing a central role, by advancing critical capabilities, supporting key programs such as the F-35 and many more, and continuing to invest in innovation and industrial excellence.

**Stéphane Burton**  
CEO - Sabena Engineering



For decades, Sonaca has been a major player in Defence, leveraging both our expertise and our robust industrial network to tackle the challenges facing us today. The European Defence sector stands out as a tremendous opportunity for Wallonia's dynamic and innovative industry, and Belgium's advanced infrastructure and skilled companies provide a solid foundation for growth. However, to truly capitalize on these strengths, we need to foster greater coordination and agility across the sector. Strengthening Europe's Defence isn't just about security—it also enhances sovereignty, drives employment, and advances technological autonomy. With this in mind, Sonaca is determined to play a central role by developing cutting-edge technologies and rapidly expanding our industrial capacity. Our aim is to help position Belgium and Europe as a leader in Defence innovation, supporting both our regional economy and broader strategic goals.

**Yves Delatte**  
CEO - SONACA



Safran Aero Boosters, a technology partner to aerospace and Defence engine manufacturers and leader in aircraft engine front-end modules, highlights its role in strengthening national Defence capabilities in an increasingly uncertain international context. Building on its strong experience in the military sector, the company has also developed advanced technologies for the commercial market. Today, it leverages these capabilities to support Defence-related challenges. Safran Aero Boosters will contribute to the F-35 program by supplying components for all Pratt & Whitney F135 engines powering the F-35 Lightning II and invests in the development of technologies for sixth-generation fighter aircraft and drones. Anchored in Belgium, the company supports the strengthening of Defence capabilities while generating economic benefits for the country and its regions.

**François Lepot**  
CEO - SAFRAN Aero Boosters



Wallonia, with its industrial and technological expertise, is facing major challenges and promising opportunities in the new geopolitical context of Defence. In this field, our region has a key role to play in strengthening European sovereignty and meeting the growing security challenges facing our continent and our Union. At John Cockerill Defence, we believe in the potential of Walloon industrial players to innovate, collaborate and position Wallonia as a key contributor in these strategic sectors. John Cockerill Defence's ability to supply complete armored vehicles makes it a major player in the land Defence systems industry.

**Thierry Renaudin**  
CEO - John Cockerill Defence



Today as Defence and aerospace company, we face significant challenges: urgent operational needs, global security dynamics, rapid technological advancements and global competition. Belgium and Wallonia's robust industrial base, with its skilled workforce, rich history of manufacturing excellence, and commitment to R&D, provides a strong foundation to position Belgium as a frontrunner in the domain. We are dedicated to leveraging these strengths, fostering collaboration and partnership throughout Belgium, and driving sustainable growth in Defence technologies to support regional and global security.

**Alain Quevrin**  
CEO - Thales Belgium



KNDS is a pan-European leader in land defence, offering advanced and interoperable mission solutions. The group integrates manned and unmanned systems into open and interoperable solutions, covering the full range of 'system of systems' capabilities as an industrial prime contractor. Its subsidiary, KNDS Belgium, has built a global reputation for the design and production of a wide range of medium and large-calibre ammunition. Based in Wallonia for nearly 80 years, it draws on a dense network of technical and human expertise, suppliers and a high-quality ecosystem that enables it to meet the challenges posed by the sector's growth.

**Jean-Michel Girard**  
CEO - KNDS Belgium S.A.





## A Strategic Sector at the Heart of Wallonia's Industry

At a time when issues of sovereignty, security and strategic autonomy are taking centre stage in Europe, Wallonia is affirming the strategic role of its defence industry. With internationally recognised expertise, it draws on a dynamic ecosystem bringing together major groups, innovative SMEs, universities, research centres and competitiveness clusters.

For nearly twenty years, the MecaTech and Skywin clusters have shaped this dynamic by fostering collaborative innovation between industry and research. This initiative, reinforced in 2022 by the Defence call for projects under the Wallonia Recovery Plan, has supported nearly 40 defence-related projects, representing over €130 million allocated by the Walloon Region to innovation in this sector.

This brochure highlights these projects and the Walloon stakeholders behind them. It illustrates Wallonia's ability to bring together its industrial, technological and scientific strengths to meet the defence challenges of tomorrow, whilst consolidating its roots in Belgium and Europe.

## The Defence Sector in Belgium: a Strong Presence in Wallonia

Belgium's defence ecosystem has expanded rapidly in recent years, now comprising more than 500 companies active in the sector, of which over 100 have defence as their core business. Of these, 58% are located in Wallonia, compared to 38% in Flanders and 4% in Brussels.

The Belgian industrial base in this field is mainly composed of small and medium-sized enterprises. In 2025, 65% of them had fewer than 50 employees, while only nine organisations had more than 500 employees, the largest of which is based in Wallonia.

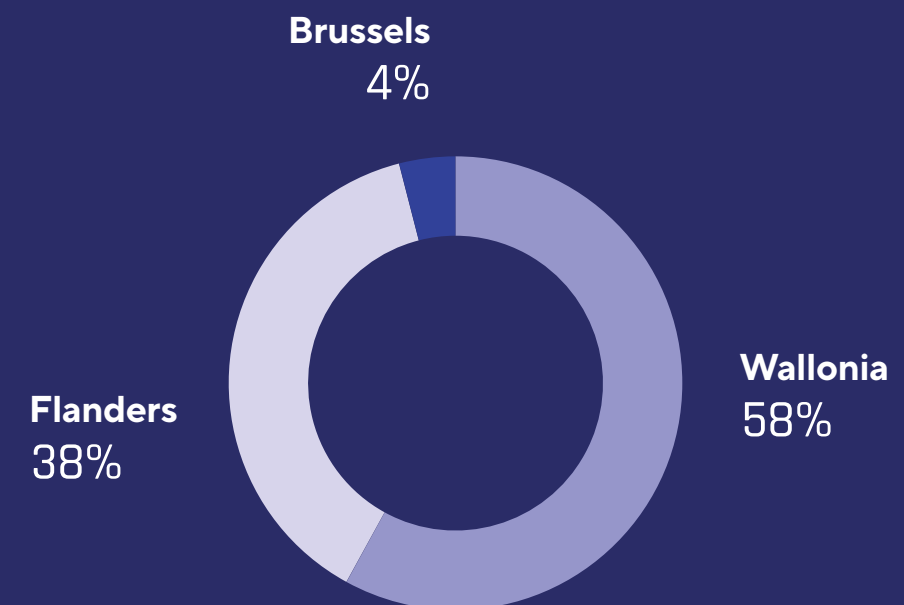

# A High Value-Added Industry in Wallonia

The Defence sector, including aeronautics, generates an estimated €6.5 billion in revenue in Belgium, of which €5 billion is generated in Wallonia.

For the specific Defence and security industry alone, the turnover amounts to €2 billion, with €1.8 billion generated in Wallonia.

In terms of employment, this sector accounts for around 5000 direct jobs in Belgium, with a concentration of 2200 direct and 5800 indirect jobs in Wallonia. It is therefore a key sector in the regional economy.

Turnover in billion / Belgium

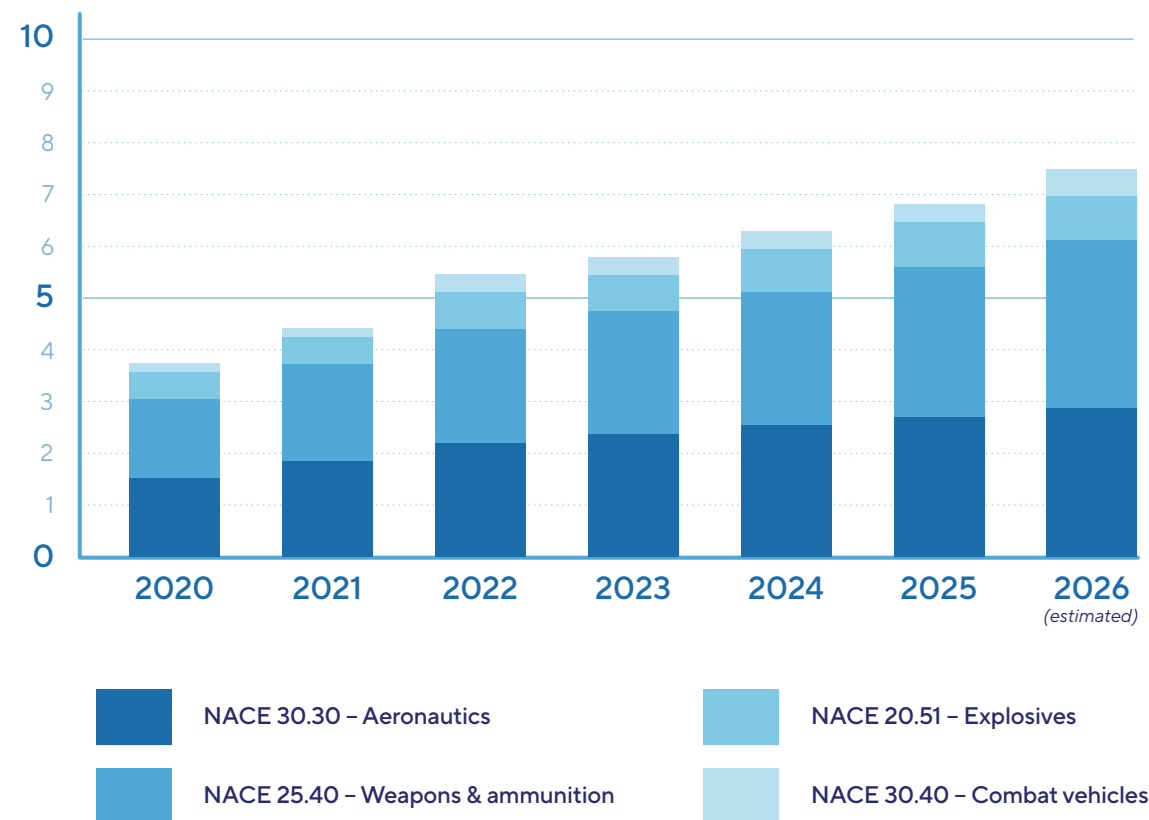

Source: Roland Berger, IBISworld, Agoria - updated with data from Agoria / BEPIDS 2025



## A Diversified and Structured Industrial Landscape

The Walloon Defence ecosystem includes around 100 companies, with a balanced distribution among:

→ Prime contractors (OEMs)

→ Subcontractors

→ Service providers

The industrial base is mainly composed of:

Component manufacturers (about 50%)

Consulting and engineering firms (25%)

CDMO/MRO players (production and maintenance)

In addition, there is a core of tech startups operating in high-value niches such as sensors, radars, X-rays, drones (UAV/UAM), artificial intelligence, and robotic targeting systems.

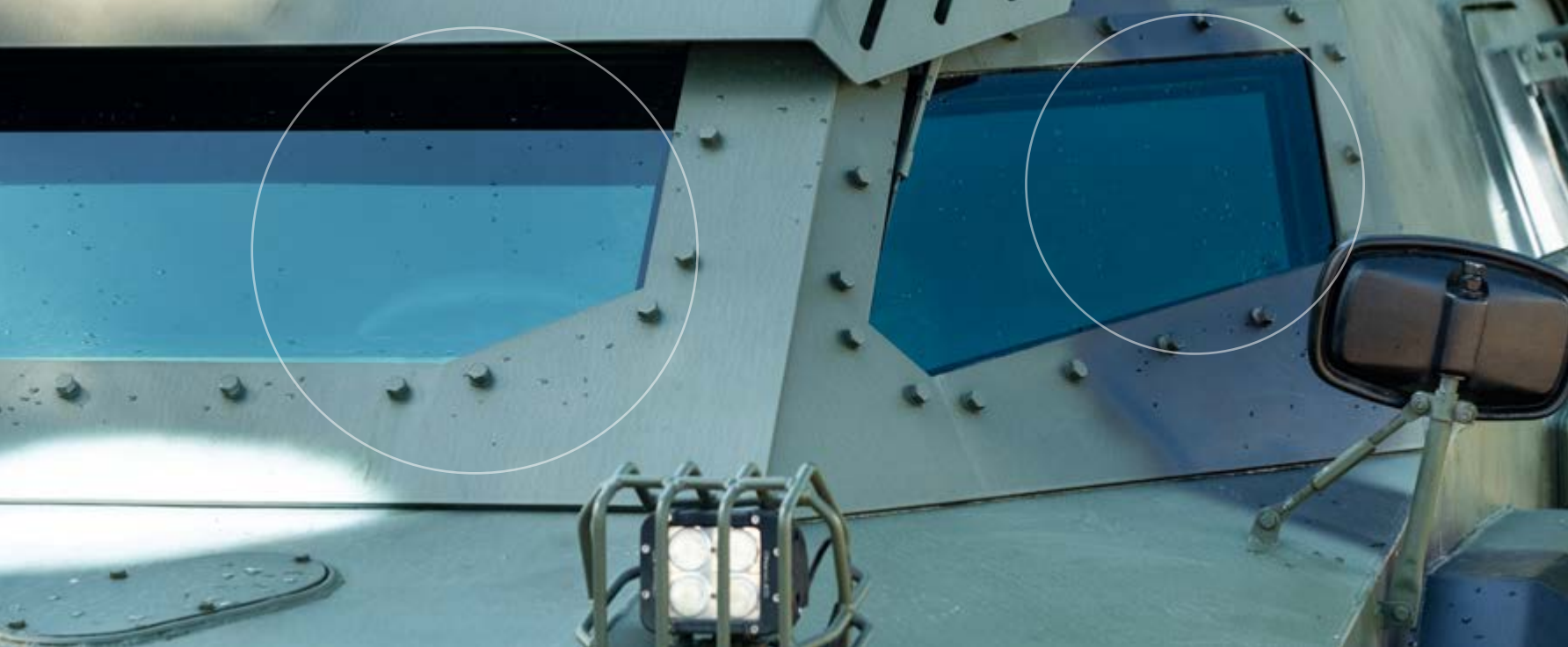

# Technological Applications Dominated by Land and Air

Most Walloon companies active in Defence focus on land-based applications, followed by aerial applications.



## LAND APPLICATIONS

A strong presence across the entire value chain

- OEMs: John Cockerill, FN Herstal, Thales Belgium, KNDS Belgium
- Subcontracting: a dense network of equipment suppliers
- CDMO/MRO
- Advanced technologies: sensors, radars, robotic targeting, X-rays
- Engineering and consulting services

The arms and munitions sector is particularly prominent with key players such as FN Herstal, KNDS Belgium, and Eurenco Clermont.



## AERIAL APPLICATIONS

A strong position includes

- Several OEMs : Safran, Sonaca
- A solid base of subcontractors
- CDMO/MRO activity: Sabena Engineering, Patria
- Innovative companies (AI, drones, X-rays)

Note: subcontracting for the aerospace sector also supplies the land sector, while the reverse is less common.



## SPACE APPLICATIONS

Space has become a central element of modern military capabilities.

Wallonia already has a strong ecosystem in aerospace, with several skills directly transferable to space defence.

It is already very well positioned as:

- a strategic European subcontractor,
- a specialist in high-value technological niches,
- a partner of ESA/NATO/European Defence programs.

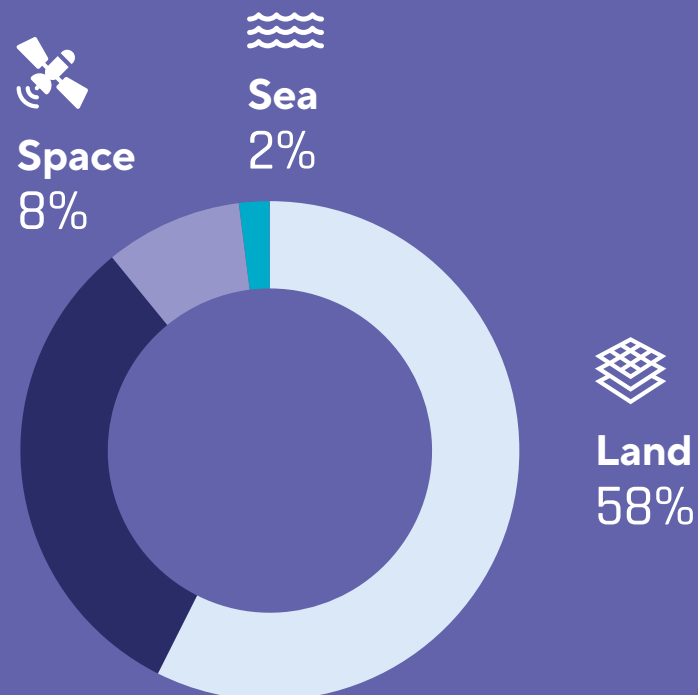

## CLEAR AND AMBITIOUS TECHNOLOGICAL PRIORITIES

Wallonia's strength lies in its capacity to innovate and integrate advanced technologies in land, air, and space domains.

The regional ecosystem is recognized for its expertise in

Advanced weaponry

Ballistic protection

Sensors

Intelligent autonomous systems

Artificial intelligence

Additive manufacturing

Collaboration between large companies, SMEs, research centers, and universities is a major driver of the sector's technological development.

Walloon companies are active in seven strategic technological areas

- Intelligent Unmanned Autonomous Systems (UIAS)
- Information processing, communication, intelligent embedded systems
- Munition/effectors systems and integration
- Structures, materials (including energetic), protection elements
- Lifecycle support & services
- Advanced aerial vehicles, control systems, and propulsion
- Space4Defence



# Collaborative Projects

# COMPIL

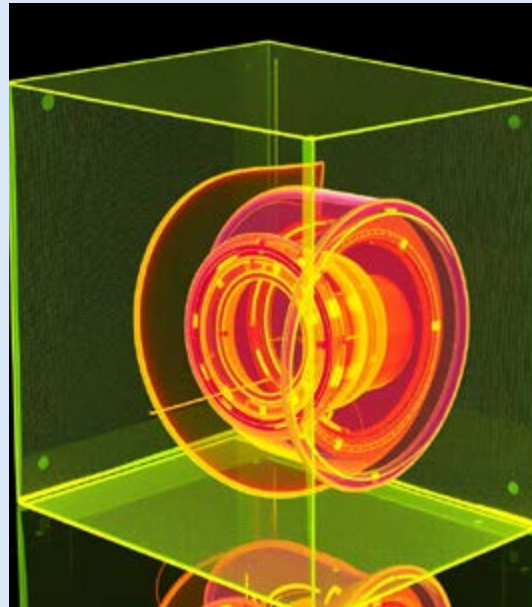

The COMPIL project aims to develop innovative in-line inspection methods for industrial quality control.

The partnership between three Walloon companies, a research center, and the University of Liège integrates advanced techniques like 3D X-ray reconstruction, stereo-photometric acquisition, and AI to detect both internal and external defects. The pilot applications include foundry part inspection, cylindrical objects, and additive manufacturing.

The goal is to offer these solutions to both local and international markets.

CONSORTIUM



# COMPOMAG



COMPOMAG is a project aiming to develop magnesium-carbon composite injected parts.

The research areas will enable the partners to implement new production methods so that industrials will be able to renew and broaden their product ranges and associated markets.

Another aim of this project is to gather the industrial firms and research units with a potential for innovation around a promising idea that will produce a breakthrough innovation if the project succeeds.

At the end of the project, the partners in the research will together proceed with the products' industrialization and production. The project should generate benefits for all the partners and make it possible to maintain and create jobs.

CONSORTIUM



# D-DAMS



## Digital Armament Management System.

An industrial consortium has been put in place in Wallonia in order to develop a new competence: develop smart electronic devices that can meet the DO178 (software) and DO254 (hardware) standards.

Those standards give the strong robustness and safety level guarantees that are expected in aeronautics. As a consequence, taking them into account from the development phase is a must when one wants to certify products. The competence of each partner will increase progressively, up to full mastery of those standards.

The projects also targets a practical case: an armament management system used for helicopters and light combat aircraft.

### CONSORTIUM



# ELECTROHOB



## The objective of the ElectroHOB project is to develop a new electronic rocket concept for illuminating mortar-type ammunition.

In the descending phase, the rocket must make precise measurements of distance to the ground in order to be able to trigger the operation of an illuminating pot at a defined height.

To allow perfect, rigorous integration in a reduced volume and to submit to extreme constraints, the research focuses on innovative concepts in microelectronics, micromechanics, turbomachines, and dynamic simulation.

The industrialization and production of the products by the partners is planned at the end of the project.

### CONSORTIUM

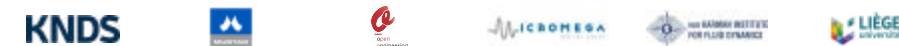

# HAVCOAT



The aims of the HAVCOAT project are to optimize powerful yet ecological amorphous hydrogenated carbon (a-C:H) surface coatings and to develop tools for producing, characterizing, and validating these surface treatments.

Namur University (UNamur) has developed an a-C:H surface coating specially designed for engine bearings; it reduces wear and the friction coefficients of these parts but can nevertheless undergo a shaping phase.

The aim of this project is to optimize both the plasma process and the coating's performance for use in high-added-value sectors. The automotive industry (racing) has already shown interest in it based on a preliminary assessment of the coating's properties. The partners BTD and DSi will be tasked with developing innovative testing and validation methods for coated bearings, including real-time wear monitoring using radiotracer techniques. That will be done in partnership with ULg, which will mark the surfaces subject to wear. JTEKT TORSEN Europe is taking part in the project with the aim of adapting the layer to TORSEN differential parts in order to improve current performance and reduce operating noise.

Finally, the company FN Herstal has shown interest in developing a version of the coating that will improve the mechanical output of the moving parts of firearms.

## CONSORTIUM



# IRIS



Today, surveillance, whether in a military or civilian context, is one of the essential elements guaranteeing the security and safety of individual property, equipment, and people.

In the interest of improving surveillance capacity, the IRIS (Intelligent Recognition Information System) project brings together the scientific and technological expertise of CMI Defence, ACIC, the Multitel research center, Liège University, and Belgium's Royal Military School to develop intelligent modules to help detect, recognize, and analyze behaviors and threats.

The innovative concept of decision-making assistance that IRIS proposes will enable surveillance operators to take up the right information at the right time to take the best decision in dealing with a given situation. Soldiers' and civilian lives, the security of sensitive sites (nuclear power plants, Seveso sites, etc.), and the safety of equipment and facilities depend on such decisions. That is why IRIS will be based on the latest innovations, especially in artificial intelligence (computer vision, machine learning, game theory, and so on) to provide the best responses for such current issues.

## CONSORTIUM



# M4

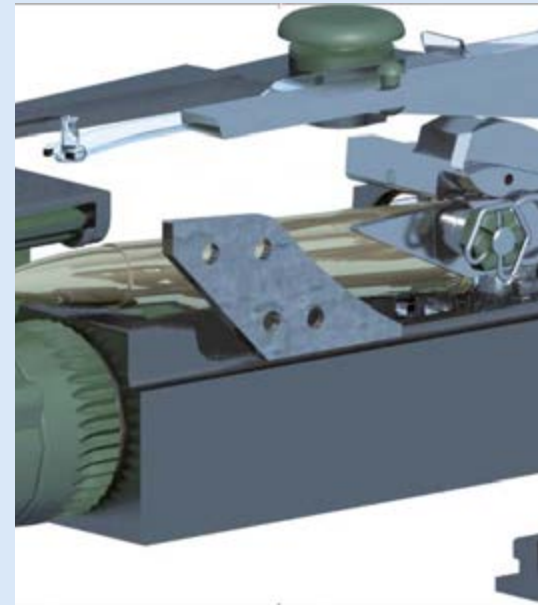

FN Herstal is coordinating an industrial research project called "M4 Multigauge Mechatronic Machine Gun."

This research project is innovative and unique in the type of application envisaged, thanks to the combination of the various technologies and disciplines involved.

A number of deliverables are expected, including:

- a new weapons development methodology that includes new technologies;
- new modeling and multiphysics simulation tools;
- the exploration and validation of new concepts;
- scale models for experimental validation of all the concepts that are covered.

The products that are developed from this project's outcomes will increase FN Herstal's global market share and employment in Wallonia.

CONSORTIUM



# MRIPF

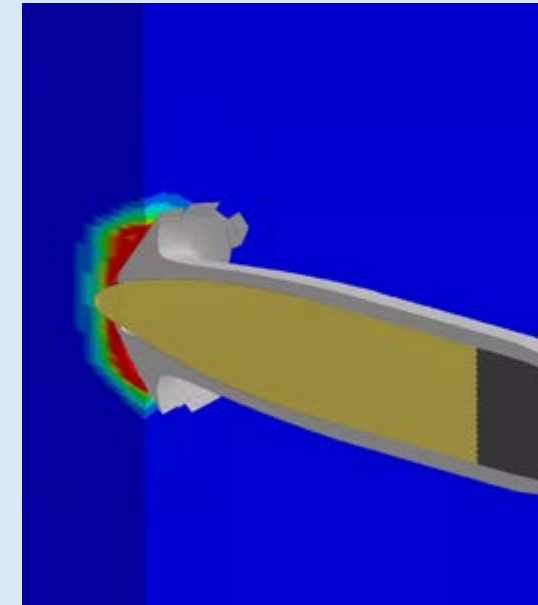

The objective of the MRIPF project is to better understand and control the phenomenon of rupture or fragmentation resulting from cracking.

This phenomenon is interesting for scientists, since it must either be excluded from certain applications or be controlled in order to orient the fragments (for example ammunition) in a certain direction (problem of collateral damage).

MRIPF aims to:

- understand the physics of the phenomenon,
- develop a database of numerical models for propagation analysis of these cracks in order to determine their behavior in industrial situations, and
- design innovative products on this basis.

A plus for the armaments market and all industrial applications related to the phenomenon of fracture!

CONSORTIUM



# NANOAPPLI



The MT\_NanoAppli project consists in optimizing the production capacities of nanopowders developed in Nano-Tech project and releasing industrial applications.

The use of nanopowders in Belgian Defence products should lead to innovative explosive and propulsion characteristics. These nanopowders will be used in existing production processes.

In order to ensure the consistency of their characteristics – and thus their lifetimes – a special coating will be developed.

The applications of this project can be extended to other sectors, such as space propulsion, safety (airbag), medicine, and so on.



# NEXT GENERATION POWDER



The aim of the NextGeneration Powder project is the development of a new spherical propellant powder with enhanced particle size and energy content characteristics through a new manufacturing procedure.

This will open the door to the medium-caliber and mortar ammunition markets while maintaining the specific features and advantages of spherical powders (flowability, loading density, etc.).

The principle will rely on incorporating a HE energy base and environmentally-friendly additives for better control of combustion than with the usual propellants.

That will enable the powder to generate more pressure and thus additional thrust for ammunition when it is fired.



# OPTIMIS



The OPTIMIS project aims to develop an innovative man-machine interface for controlling John Cockerill Defence's land-based weapons systems.

Aiming to bring a new dimension to the control of land weapon systems through a new modality approach, the OPTIMIS project (Optimised Personal Turret Interface based on a Multimodal Interaction System) brings expertise of John Cockerill Defence, NexVision, Acapela, Multitel, the University of Namur, and the Royal Military Academy to develop a human-machine interface device worn by the operator, with the objective of enabling the control of John Cockerill Defence weapon systems in a completely innovative, efficient, and above all intuitive manner for the operator.

The OPTIMIS project mainly relies on a device (helmet) worn directly by the operator, comprising an intelligent multimodal engine that manages the information from the weapon system and the interaction modalities, which will be visual, auditory, vocal and haptic in nature.

All this to ensure a measured control of the operator's cognitive load during the mission. The interface becomes intelligent, immersive, and uses the natural interaction codes of human beings.

CONSORTIUM



# PEA



The aim of the project is to develop a powder for small-caliber firearms to reduce barrel erosion when they are fired.

The PEA project is led by Eurenco Clermont and FN Herstal, in partnership with Belgium's Royal Military School and Liège University in a tight economic context characterized in particular by the price war caused by the massive unloading of U.S. products at low prices on the European market.

This already innovative project on the world stage is a breakthrough innovation in the small arms ammunition market. These major technological advances will enable both Eurenco Clermont and FN Herstal to bring to market innovative products that will create a real differentiation likely to lead to significant economic development and the long-term sustainability, and even growth, of industrial employment in the Walloon region.

CONSORTIUM





The aim of the SBSS project is to develop an innovative sonar system for the rapid and effective detection of buried and bottom mines in marine areas.

Specifically, buried mines represent a capability gap in European navies and more generally in navies worldwide.

The SBSS project objective is to develop a breakthrough sonar system to detect currently invisible mines, mainly buried mines and hidden bottom mines, such as those in seagrass beds. The use of a low frequency sonar is justified by the ease with which acoustic waves propagate in the marine environment and their ability to detect all types of objects, whether ferrous, metallic, or non-metallic.

CONSORTIUM



Smart-Pod System. The objective of the project is to combine various Walloon partners' competencies to conduct research for the development of a Smart-Pod System, i.e., an embedded container for aircraft, carrying a machine gun and 12.7mm guided rocket tubes.

The Smart-Pod System will be developed in parallel with the viewfinder Hudi, launched by FN Herstal, and its functional connection. Regarding Smart-Pod, the lines of research are:

- optimized aerodynamics, aero-thermal and acoustical design of the composite cell,
- digitization of the control electronics,
- embedded software,
- a new amortized cradle,
- a new cartridge box,
- the necessary interfaces for installation and shooting of guided rockets,
- the integration of all these different components,
- and validation tests for aviation standards.

The objective of this project is also to bring together SMEs with innovation potential around the FN Herstal Group, enabling them to grow and gain experience in the aviation industry.

CONSORTIUM





The aim of the SWS project is to integrate a fully electronic firing chain into a weapon.

**This integration requires study of the following technological blocks:**

**Secure communication:** In the era of the Internet of Things, it is important to be able to communicate with weapons as transparently as possible.

**Electronic activation:** The ammunition can be detonated either electromechanically (e.g., electronically controlled striking pin with traditional ammunition) or electrically (in which case an electrical signal activates the primer cap).

**Electrical priming:** If the heart of the weapon becomes totally electronic, the ammunition must be changed along the same lines to ensure its maximal integration in this development. The consortium works on developing new primer cap compositions and structures.

**Energy recovery:** A weapon necessarily releases a huge amount of energy. However, it is not easy to have the right energy at the right time (before the first shot), nor is it easy to convert the energy effectively, given that the energy is released in pulses. Both of these aspects are studied in this project.

A new optimized weapon architecture will thus be developed on the basis of these different technological blocks.

CONSORTIUM



Smart Integrated Guided Rocket Development.

The aim of the Smart Integrated Guided Rocket Development (SIGURD) project is to bring together FN Herstal (FNH), Thales Belgium (TBE), GDTECH, JD'C Innovation and Sobelcomp, as well as the Sirris and CRM Research Centers to conduct research that will develop and integrate the Thales laser-guided rocket fire capability into FNH's aero-digital product range.

This project will focus on the integration of a rocket launcher module with the S-Pod range, mechanical and digital interfaces, a lens protection solution for the seeker device and the integration of the "Lock-On Before Launch" capability of the Thales guided rocket in FNH's DAMS.

At the end of the project, the developments will be industrialized by the partners before they proceed to series production. The marketing will be done by the FNH and TBE through their respective commercial networks. The project will have shared benefits for partners and help maintain and create jobs.

CONSORTIUM





The VIRGA project aims to protect military troops by developing an innovative stealth and security solution.

Today's and tomorrow's theaters of military action are and will be increasingly uncertain (little control over the environment, great geographical diversity), with means of detection and threats (ammunition, etc.) that are constantly rising.

There is thus a desire to put the human being, i.e., human safety, at the heart of military concerns.

The aim of VIRGA is to develop a comprehensive solution that meets the requirements of the stealth frequency spectrum in a mission scenario:

- Not detectable/visible at long range (12-22 km)
- Not recognizable at medium range (4-12 km)
- Not identifiable at the short range of engagement (<4 km)

VIRGA will thus include passive solutions (IR/Radar) to reduce the armored vehicle's signature, but also active solutions making it possible to change the vehicle's signature (thermal signals) and mislead the adversary at close distances (radar). These active solutions will be driven dynamically and intelligently through an AI-based analysis-and-detection system.

#### CONSORTIUM



Advanced Collaborative Land Defence

PRW Defence – 2022  
Budget: €4.6M

In the context of the digital transformation of defence systems, the ACOLAD project aims to strengthen collaborative multi-weapon capabilities. It is part of the transition towards interconnected systems capable of processing and sharing data in real time, while addressing resilience and security challenges.

The project develops a solution enabling the exchange, analysis and visualization of data from embedded sensors, in order to optimize target acquisition and coordinated engagement at battalion level. It also integrates functionalities for the remote operation of unmanned systems.

**Domains :** Digital – ICT

#### PARTNERS



# CRESCENDO



## Cyber RESilienCE iN Defence Operation

PRW Defence – 2022  
Budget: €5.8M

In the context of increasing cyber threats and the digitalisation of defence systems, the CRESCENDO project aims to strengthen the resilience and security of military communication infrastructures. It is part of the broader effort to enhance the autonomy and cooperation of European armed forces within an NATO framework.

The project addresses interoperability challenges between defence systems developed at national level, enabling the secure and seamless exchange of sensitive operational information. In doing so, it contributes to improved coordination and effectiveness of joint operations.

CRESCENDO develops advanced end-to-end security solutions for military communications and interconnected systems, while reinforcing capabilities for control, configuration, and protection of data exchanges. The project also explores emerging cybersecurity technologies applied to defence applications.

**Domains :** Digital – ICT

### PARTNERS



# SProtector



## Smart Protector

PRW Defence – 2022  
Budget: €5.2M

The SProtector project aims to reduce collateral damage associated with the use of kinetic less-lethal launchers. It is part of a broader effort to improve accuracy and control in law enforcement and defence operations.

The project develops a solution combining an intelligent aiming accessory with an integrated training support system. The objective is to enhance operator precision and reduce operational errors through real-time feedback in both live use and training environments.

SProtector also addresses the need to improve training efficiency under time constraints, by providing tools that identify performance gaps and support targeted skill development for operators.

**Domains :** Digital – ICT – Mechanical Engineering

### PARTNERS



# HUMSnet



## Health & Usage Monitoring System networked systems

PRW Defence – 2022  
Budget: €3.5M

In the context of the increasing digitalisation of weapon systems, the HUMSnet project aims to improve the collection, quality, and exploitation of data generated by Health and Usage Monitoring Systems (HUMS). It is part of the transition towards interconnected and collaborative defence systems.

The project focuses on structuring and centralising HUMS data to enable its use beyond the originating subsystems, particularly for maintenance support and enhanced operational performance. It contributes to the evolution towards systems-of-systems capable of sharing their status and performance in real time.

HUMSnet is based on standardised interoperability protocols and advanced data processing approaches (including data mining), with potential applications extending to critical infrastructure monitoring.

**Domains :** Digital – ICT – Mechanical Engineering – Logistics

### PARTNERS



# TARANIS

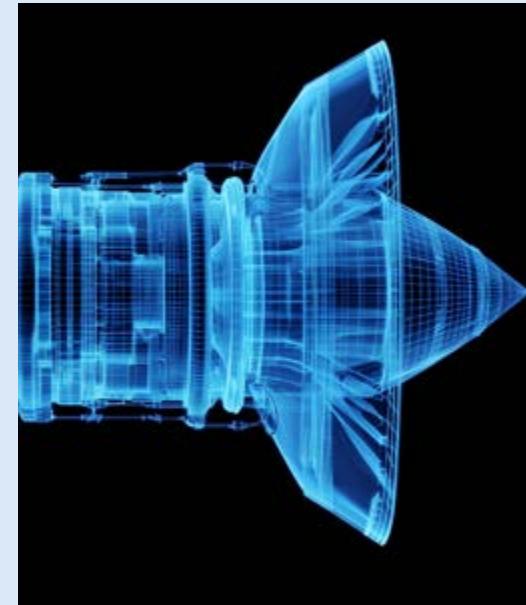

## Long-range Anti-dRone Air Defence syStem

PRW Defence – 2022  
Budget: €1.9M

The TARANIS project aims to develop and characterise a propulsive vector dedicated to long-range counter-UAV operations (several kilometres). It addresses the need for effective, easy-to-use, and cost-efficient solutions for drone neutralisation beyond currently available ranges.

The research focuses on the design of an innovative propulsion system incorporating more environmentally friendly materials and improved lifetime performance. It also includes the development of adapted ignition systems, thermal protection solutions, and performance simulation and validation models.

In addition, the project explores advanced predictive maintenance approaches, including embedded sensing and propulsion system health monitoring, in order to improve reliability and operational safety.

**Domains :** Aerospace – Green Chemistry – Materials Chemistry  
Mechanical Engineering

### PARTNERS





## Optimised Heat Exchanger for Severe Environments

PRW Defence – 2022  
Budget: €3.0M

The ECOPES project aims to develop a high-performance heat exchanger for defence applications, addressing increasingly stringent requirements in terms of power density, compactness, and resistance to extreme operating conditions.

In modern military propulsion architectures, thermal management is a critical challenge. The project focuses on designing an innovative, compact and integrated heat exchanger leveraging additive manufacturing technologies to reduce onboard mass while improving thermal efficiency.

Development activities include the optimisation of geometric design and aero-thermal performance, the reduction of pressure losses, and the development and validation of design and simulation models. A demonstrator will be manufactured and tested under representative operating conditions to validate system performance.

**Domains :** Aerospace

### PARTNERS



## Resource management for Unmanned Distributed Intelligent System

PRW Defence – 2022  
Budget: €9.2M

The RUDIS project aims to develop a distributed architecture for weapon systems operating in a potentially unmanned mode. It addresses the increasing need for autonomy, modularity, and flexibility in modern defence systems.

The project focuses on intelligent distributed resource management, including power management, video stream handling, and core functions such as threat detection, recognition, and identification. It also covers effector management within a framework of local autonomy.

RUDIS contributes to the development of more autonomous systems capable of coordinated operation in complex and distributed environments.

**Domains :** Digital – ICT

### PARTNERS



# Walloon Defence Actors

Companies





## HEAD OFFICE

Boulevard Initialis 28  
7000 Mons

## CONTACT PERSON

**Christophe Parisot**  
CTO

## CONTACT DETAILS

+32 65 39 43 80  
cparisot@chapsvision.com

Since 2003, ACIC develops innovative VCA solutions and AI technologies based on its own neural networks for automated and intelligent video surveillance.

From security to datamining, ACIC provides tailor-made solutions. They can be used with any IP cameras or on the Edge with compatible models. In the security sector, we have field proven solutions deployed all over the world for intrusion detection over sensitive areas and perimeters such as refineries, military sites, airports, border surveillance, coastal surveillance and many other sensitive perimeter protection (media, nuclear plants, pharmaceuticals...).

These state-of-the-art products are the result of intensive continuous internal and collaborative R&D projects. As an example, the current co-funded RUDIS project (Wallonia's recovery plan) is dedicated to the detection of threats in the wild (military scenarios) and will enhance our solutions for surveillance through innovative technologies.

**Specific competences: Image and video processing combining signal processing and AI technologies. Integration on several platforms, with many SDKs and hardware's (Linux and Windows).**



## HEAD OFFICE

Rue de l'Avouerie 7  
4000 Liège

## CONTACT PERSON

**Pierre-Philippe Janssen**  
CEO

## CONTACT DETAILS

+32 42 54 50 11  
info@advco.be

Advanced Coating designs, develops and applies plasma and supersonic (HVOF, HVAF) spraying of metals, alloys, abrasives, ceramics and carbides on technical parts.

Coating specifications :

- Wear resistance : abrasion – erosion; cavitation – fretting.
- Corrosion protection.
- Heat and oxidation resistance.
- High temperature protection/Thermal barrier.
- Clearance control – abrasives and abrasives.
- Electrical resistivity & conductivity.

We are also specialist in flat and cylindrical grinding as well as superfinishing and dynamic balancing of parts. We are specialized mainly in Space, Defence and Aeronautics industries. Advanced Coating is EN9100 & NADCAP Coatings certified.

# Aerospacelab

SECTORS



# AgiNtech

SECTORS



**Founded in 2018, Aerospacelab has established itself as a key player in developing, manufacturing, and operating cutting-edge Earth Observation and Telecommunications satellites at scale.**

In 2024, the successful acquisition of AMOS marked an important milestone, further enhancing optical capabilities and introducing high-end payloads to Aerospacelab's growing portfolio, while strengthening its global position.

Manufacturing at scale is a core component of Aerospacelab's DNA. From developing individual subsystems to building complete satellite platforms, and even delivering turnkey satellite missions, Aerospacelab combines technical expertise with an innovative mindset to meet the diverse needs of its customers. This end-to-end approach ensures efficiency, reliability, and adaptability across all stages of production.

With operations strategically positioned, including its Headquarters in Belgium and a factory in the U.S. (California), Aerospacelab is able to deliver innovative solutions to an expanding customer base worldwide. In 2026, Aerospacelab is set to unveil The Megafactory, Europe's upcoming largest satellite manufacturing facilities, demonstrating its ambitious vision to shape the future of the aerospace industry.

#### HEAD OFFICE

Rue André Dumont 14b  
1435 Mont-Saint-Guibert

#### CONTACT PERSON

**Célia Berlemont**  
Senior Communications,  
Marketing & PR Manager

#### CONTACT DETAILS

info@aerospacelab.com

[www.aerospacelab.be](http://www.aerospacelab.be)



AgiNtech offers integration solutions in electricity, automation, robotics and industrial IT (MoM/MES) including network implementation and cyber security to optimize our customers' production processes.

We position ourselves as a one-stop shop solution for Industry 4.0. We are building an ecosystem of partners who complement our offering and share our values. Our scope extends from basic studies to on-site commissioning, in the manufacturing and process industries in general. We also have expertise in design and installation in ATEX zones. In the context of Industry 4.0, we have an offering that we make accessible to SMEs through solutions designed and developed specifically for them.

Our cybersecurity offer is unique on the market, as we propose to be the single point of contact for IT and OT. We are also offering a MES platform, fully sovereign with local AI capability or connected AI. This platform is dedicated to the Industry from the data collection (on a cybersafe way) to the optimization.

#### HEAD OFFICE

Rue Emile Vandervelde 56C  
5190 Ham-sur-Sambre

#### CONTACT PERSON

**Christophe Camerlynck**  
CEO/Managing Director

#### CONTACT DETAILS

+32 71 256 280  
christophe.camerlynck@agintech.eu

[www.agintech.eu](http://www.agintech.eu)

**Specific competences: Manufacturing automation, robotic, mecatronic and special machines.**

SME

# Alkar Technology

SECTORS



SME

# Altéris Technologies

SECTORS



**We are a small company specialized in High Performance Composite Materials.**

We can take over projects at different stages : engineering, structural calculation, composite laminate analysis, finite element analysis of both laminates and structure, design, toolings, prototyping, validation testing (materials and elements), production.

We always put the emphasis on processes that will produce high quality parts with the best performances (optimised fiber volume ratio and low porosity) : autoclaved prepregs, Resin Transfer Moulding and vacuum infusion using Airbus' patented double bag process. We also produce composite references for Non-Destructive Testing, namely references for delamination, foreign objects, ply waviness, dry spots and porosity using our proprietary method.

All NDT references are produced using any material / process. We currently produce these references for the whole aviation sector in Belgium and some clients abroad.

HEAD OFFICE

Rue Albert 1er 46 B23  
7134 Leval-Trahegnies

CONTACT PERSON

**Alain Kinard**  
Managing Director

CONTACT DETAILS

+32 64 65 20 82  
alki@alkartechnology.com



**Altéris Technologies is an electronics design office, from product conception to industrialization.**

Backed by a solid network of European partners, Altéris can support its customers right through to the final production phase. Specializing in ultra-low-power electronics and energy recovery, Altéris develops sensors capable of withstanding extreme environmental conditions (temperature, vibration, shock, radiation, etc.).

In addition to measuring a wide range of parameters, our sensors can incorporate sufficient computing capacity to perform complex operations (edge AI), thus reducing the need for remote communications. These sensors can also incorporate a wired or wireless communication layer compatible with the system's ultra-low power requirements (Bluetooth, ZigBee, Thread, LORA, SigFox, etc.).

In addition to sensors, we are also developing microactuators that enable local action

HEAD OFFICE

Chemin de la Platte 81  
4845 Jalhay

CONTACT PERSON

**Hugues Libotte**  
CEO/Managing Director

CONTACT DETAILS

+32 473 21 94 91  
hli@alteristechnologies.com

**Specific competences: Sensors development, sensor network, actuator, harsh environment electronic integration, IoT.**

SME

# ALXSystems (Phoenix-Dynamics SRL)

SECTORS



LC

# AMOS

SECTORS



We provide Autonomous UxS, combat oriented, tested in Ukraine, to fulfil mainly 3 missions :

Autonomous kamikaze drones (ALM), Drone interceptor small drones (FPV) and drone interceptor for Fixed wing drone (Shahed,...), and ISR/photogrammetry/3D Mapping.

#### HEAD OFFICE

Rue de la résistance, 26/1  
4681 Hermalle-sous-Argenteau

#### CONTACT PERSON

Geoffrey Mormal  
CEO

#### CONTACT DETAILS

+32 473 523 020  
mormal@alxsys.com



#### HEAD OFFICE

Rue des Chasseurs Ardennais 2  
4031 Liège

#### CONTACT PERSON

Xavier Verians  
Director Business Development

#### CONTACT DETAILS

+32 4 361 40 40  
xavier.verians@amos.be

AMOS designs and manufactures high-precision optical and mechanical systems, for space, big science, optical communications, Defence, and industry. AMOS delivers solutions that combine innovation with meticulous craftsmanship, to customers across Europe, the United States or India amongst others.

- **Space: very high-resolution imagers and hyperspectral spectrometers** for Intelligence, Surveillance and Reconnaissance applications
- **Ground Telescopes for Space Situational Awareness:** space objects detection, identification or tracking, with size range from 80cm to 4m diameter
- **Optical Ground Station for laser-based applications:** for optical communications, quantum key distribution, satellite laser ranging or target illumination
- **Optical manufacturing:** Mirrors of all sizes for space-based or ground-based applications, in vitroceramic, metal or Silicon Carbide, for high-resolution imaging or laser-based applications
- **Test systems:** mechanical, optical systems or thermal-vacuum chambers

# Any-Shape

SECTORS



# Balteau NDT

SECTORS



AnyShape is a Belgium-based additive manufacturing and engineering company delivering high-end, certified solutions (ISO 9001, EN 9100, ISO 13485) for critical sectors such as Defence, aerospace, and medical. Acting as a fully integrated partner, we support customers from design to serial production, ensuring compliance with the most stringent industry standards..

Specialized in metal and polymer additive manufacturing, AnyShape produces complex, optimized, and qualified components. Our in-house engineering team provides advanced support including design for additive manufacturing (DfAM), process optimization and industrialization for serial production.

For Defence applications, we develop high-performance solutions leveraging design freedom to integrate, e.g. advanced thermal management features such as conformal cooling channels and lattice structures, while reducing weight and improving system reliability. Our expertise in advanced materials and design optimization enables performance levels beyond conventional manufacturing.

As one-stop-shop service provider, AnyShape also ensures full post-process, quality control, and secured production aligned with the needs of resilient European Defence supply chains.

#### HEAD OFFICE

Rue des Technologies 1  
4530 Villers-le-Bouillet

#### CONTACT PERSON

**Roger Cocle**  
CEO

#### CONTACT DETAILS

+32 42 23 00 95  
sophie.giaux@any-shape.com



#### HEAD OFFICE

Rue Voie de Liège 12  
4681 Hermalle Sous Argenteau

#### CONTACT PERSON

**Olivier LEMAIRE**  
Sales Manager

#### CONTACT DETAILS

+32 4 374 75 75  
sales@balteau-ndt.com

With unparalleled expertise in radiographic solutions, BALTEAU NDT S.A. offers a comprehensive range of portable X-ray generators, combining high power, light weight, and proven reliability.

A true industry benchmark, BALTEAU NDT stands out with its manual and automatic systems for conventional and digital radiography (DR), designed to meet the most demanding non destructive testing requirements.

Since 1936, the Belgian company has been putting its know-how at the service of industry, deploying hundreds of inspection systems worldwide.

Today, these systems are used across a broad spectrum of applications, including automotive, shipbuilding, aerospace, Defence, foundries, gas cylinder manufacturing, piping production, research centers, and museums.

Renowned for its innovation, robustness, and precision, BALTEAU NDT remains the trusted name in X-ray reliability.

# Base de Baronville

SECTORS



# BEBLUE CRYOTECH S.A.

SECTORS



The Base de Baronville has all the necessary authorizations to store explosives, weapons, ammunition or other military equipment.

To this purpose, we operate a 155-h site, located halfway between Brussels and Luxembourg.

Our 25,000 m<sup>2</sup> of storage are equipped with state-of-the-art security and surveillance equipment and are under the permanent vigilance of approved guards.

Our qualified staff and handling equipment allow us to carry out the unloading and shipping of your goods; whether in trucks or sea containers.

#### HEAD OFFICE

Rue Lieutenant Tholomé 23  
5570 Beauraing

#### CONTACT PERSON

**Denis Robin**  
Managing Director

#### CONTACT DETAILS

+32 82 779 110  
denis.robin@base-baronville.be

**Specific competences: Logistics**



BEBLUE is a cryogenic expert in propulsive systems testing. With a legacy of 30 years of expertise in cryogenic fluids, BEBLUE is one of the 4 recognized ESA test centre. We are proposing engineering & testing capabilities with cryogenic fluids, namely Hydrogen, Oxygen and Nitrogen both liquid or gaseous and green propellants like hydrogen peroxide.

We propose:

1. a full range of material characterization in every condition (20K, 1000 bars, H2, H2O2..)
2. a wide range of test means for valves, thruster, turbopump, e-pump, components qualification.

We own all test facilities including:

- vacuum chamber for hot fire testing for complex components testing in real conditions.
- Test benches up to 400 bars for fluidic technologies developments
- Adiabatic compressors up to 1000bars for specific material testing
- Fuel cell test benches up to 400kW
- Cleanrooms

Typically supporting new propulsive systems like satellite thruster, hypersonic propulsive systems, H2 technology.

A proven expertise with all European stakeholders through qualifications of new propulsive systems.

We are ISO9001 and EN9100.

#### HEAD OFFICE

Grande Traverse 3  
4000 Liège

#### CONTACT PERSON

**Jerôme d'Agruma**  
CEO

#### CONTACT DETAILS

+32 472 862 639  
info@beblue.be

[www.beblue.be](http://www.beblue.be)



## BeCOVER

BeCOVER is an independent test center dedicated to compressor testing for both civil and military applications. BeCOVER has the ambition to support engine developments for the next 40 years.

Its configuration and performance are designed to meet future developments in the aeronautical industry. Moreover, the wide range of performances coupled with the capacity to carry out altitude tests for all operability conditions makes BeCOVER a unique facility in Europe.

With an installed power of more than 20MW, upgradable to 40MW, closed loop capability and the integration of dual and triple flow configurations, BeCOVER can test the current and future compressor configurations.

Financed at 75% by the Belgian regional and federal institutions, BeCOVER is the ideal partner to accompany the upcoming R&T and development programs by providing to the defence actors a state-of-the-art facility which meets the most stringent requirements, on a performance, capability and security point of view.

### HEAD OFFICE

Rue du Fond des Fourches 23A  
4041 Vottem

### CONTACT PERSON

**Olivier Servais**  
General Manager

### CONTACT DETAILS

+32 494 44 85 65  
info@becover.eu

**Specific competences : Research and development testing**

## BLINQY

BLINQY is a Belgium-based engineering firm that designs and develops wireless ultra-low-power sensor. BLINQY is expert in embedded firmware and smart sensing solutions.

With expertise in real-time data acquisition, embedded cryptography, edge computing, and wireless communication (Bluetooth LE, sub-GHz,..), BLINQY builds embedded software that powers IoT sensors for tracking, diagnostics and control.

BLINQY is able to develop devices that can operate in rugged, mission-critical conditions involving vibration, shock or high temperatures.

### BLINQY engineers are contributing to:

- Secure and energy-efficient communication systems
- Logistics and asset tracking through real-time location systems (RTLS)
- Sensor integration (movement detection, condition monitoring, etc.)
- Energy consumption optimization

Specific competences: Embedded Firmware Development (sensors, tags), Ultra-Low Power System Design, RTLS (Real-Time Location Systems IoT), Edge Computing for IoT Devices, Wireless Communication Protocols, Cryptography, Sensor Integration (Motion, Temperature, Shock, etc.), Data Encryption & Secure Bootloaders.

### HEAD OFFICE

Avenue General Michel 1E  
6000 Charleroi

### CONTACT PERSON

**Thibaut WIAME**  
CEO

### CONTACT DETAILS

+32 71 45 26 31  
info@blinqy.be

# Breuer Technical Development (BTD)

SECTORS



# BSOLUTIONS

SECTORS



**BTD is a service provider and reliable IC engine development partner for more than 25 years. We develop efficient solutions for high demands for well-known companies in the automotive industry.**

We are currently involved in the EU Project IPCEI Hy-2Move. Our project consists in the building of an independent test centre for industrial partners and institutions dedicated to H<sub>2</sub>, E-FUELS and FUEL CELLS. Supported by the Walloon Region, the project is notified.

From around mid-2025, we'll be operational. The new test centre integrates a test cell for harsh conditions, as altitude and tests up to -30°C (space : 4 x 4.70 x 2.3m). BTD will test properties of E-Fuels, fuel cells and the behaviour of IC engines or components (incl. other than for automotive purposes) in various conditions.

Service range : initial design-development / mechanical construction / production of prototypes, sub-assemblies and complete engines / tests & measurements of IC engines up to 1 MW and non IC drive trains.

#### HEAD OFFICE

Avenue de Norvège 6  
4960 Malmedy

#### CONTACT PERSON

**Ernst Breuer**  
Manager / Owner

#### CONTACT DETAILS

+32 80 79 15 50  
info@btd.be



**For 25 years, BSolutions (engineering consultancy), has been designing buildings by bringing together key expertise : structural engineering, MEP, H&S coordination, sustainable development, BIM, architecture, infrastructure and project management.**

BSolutions deploys integrated engineering inspired by the principles of Industry 4.0. and meets the highest standards in terms of processes, safety and data protection.

Recognised internationally for its expertise in sustainable development (COP23 winner) and BIM, BSolutions brings together 90 experts organised into specialised teams. The firm also has extensive experience in the defence, airport and aerospace sectors, handling sensitive projects: assignments for airports, a cyber security centre for the ESA, redundant and autonomous systems, a satellite megafactory, and projects subject to military standards and defence security clearances.

#### HEAD OFFICE

Rue Louis Genonceaux 12  
5032 GEMBLOUX (Isnes)

#### CONTACT PERSON

**Olivier De Temmerman**  
Manager Business Development

#### CONTACT DETAILS

+32 81 56 01 70  
info@bsolutions.be

SME

# Calyos

SECTORS



SME

# Capaul

SECTORS



Calyos has developed unique two-phase cooling solutions that allow cooling of electronic components using the latent heat of vaporisation. Two-phase cooling technologies like Loop Heat Pipe (LHP), Pulsating Heat Pipe (PHP) and Micro-Channel Heat Pipe (MCHP) technologies are fully passive, do not need power nor a pump to function and offer promising solution for addressing new thermal management challenges.

In the Defence sector, two-phase cooling technologies are crucial for managing the thermal challenges posed by advanced electronic systems in military equipment. These systems provide superior thermal efficiency by leveraging the latent heat of vaporization, enabling compact and lightweight designs essential for portable and space-constrained applications. The uniform cooling reduces thermal hotspots, enhancing the reliability and longevity of critical components in military vehicles, radar systems, and communication equipment. Their adaptability allows for integration into a variety of Defence applications, from battlefield electronics to aeronautic systems. Additionally, the improved efficiency of two-phase cooling reduces energy consumption and operational costs, contributing to more sustainable and effective Defence operations.

Calyos, as expert in the field of two-phase cooling technologies, can support in the design and the development of two-phase solutions for your target Defence applications.

**Specific competence : Thermal**

[www.calyos-tm.com](http://www.calyos-tm.com)



**For more than 150 years, one thing has remained constant at Capaul: we keep our promises!**

When processing mechanical components for a wide range of industries, you, as our customer, can always be assured that we manufacture serial parts and assemblies for you with the highest precision at fair prices. As a medium-sized company we can react quickly and flexibly, guaranteeing you reliable, on-time delivery.

Creative minds with a wealth of expertise guarantee high-level precision work across our 6,000 m<sup>2</sup> production area - 2,000 m<sup>2</sup> of which is air-conditioned. All our products are manufactured strictly in accordance with any specifications, complying with the most stringent test criteria and monitored in accordance with ISO EN9100:2016.

Located in Eupen, in east Belgium, our family-run company is right on the doorstep of the industrial regions of Liège (B), Maastricht (NL) and Cologne (D).

HEAD OFFICE  
Industriestraße 39  
4700 Eupen

CONTACT PERSON  
**Tom Henkes**  
CEO

CONTACT DETAILS  
+32 87 59 55 60  
[inquiry@capaul.be](mailto:inquiry@capaul.be)

[www.capaul.be](http://www.capaul.be)

# Carat Duchatelet

SECTORS



# Castingpar Group

SECTORS



Carat Duchatelet is internationally recognized as the world leader in manufacturing specialty vehicles in the automotive industry, mainly for Head of State security vehicles but also for design and small series production of Defence products in Land System sector such as APC's, up-armor kit, etc.

#### HEAD OFFICE

Rue Winston Churchill 413  
4020 Liège

#### CONTACT PERSON

**Vincent Lambert**  
CEO

#### CONTACT DETAILS

+32 491 15 52 25  
v.lambert@caratbyduchatelet.com



#### HEAD OFFICE

Chaussée de Mons 89  
7180 Seneffe

#### CONTACT PERSON

**Baptiste Falmagne**  
Business Developer

**Edward Rabendzki**  
Sales Director

#### CONTACT DETAILS

0032 64 522 000  
baptiste.falmagne@castingpar.com  
edward.rabendzki@castingpar.com

For 70+ years, **CASTINGPAR** is a NATO-leading manufacturer of high-precision castings in carbon steel, stainless steel and titanium for aerospace, defence and highly demanding industries.

#### Production capacities:

- Steel and stainless steel air-melted castings (lost-wax castings): from 1g to 30Kg/part and 40cm diameter
- Titanium centrifugal vacuum castings (lost-wax + sand castings): up to 450Kg/part and 250cm diameter. NATO's largest titanium centrifugal foundry by capacity
- Precision machining: machine fleet for CNC milling and turning

#### Potential applications:

Weapon parts, lightweight arms, aircraft engine parts, aircraft structural castings, missile parts, seawater pumps and chillers, etc.

#### Integrated approach:

Turnkey solutions for the most demanding customers: build-to-print parts from co-engineering and prototypes (SLA for rapid prototyping) to serial production (in-house NDT: 3D scanning, X-Ray, FPI controls)

#### Certifications:

AS/EN9100, NADCAP, ITAR-compliant

#### Steel, carbon steel, and stainless steel air-melted castings (lost-wax castings):

from 1g to 30Kg/part and 40cm diameter



## HEAD OFFICE

Rue Louis Plescia 7  
4102 Seraing

## CONTACT PERSON

**Philippe Hermant**  
Sales & Business Developer

## CONTACT DETAILS

+32 4 240 14 25  
violette.marbehant@cilyx.eu

**CILYX specializes in the design, development, manufacturing and integration of turnkey industrial equipment, with a strong expertise in test benches, production systems, and high-value mechatronic machines.**

Supported by a comprehensive in-house engineering office – covering mechanics, electricity and electronics, automation, robotization, industrial vision, energy and fluid systems – CILYX manages the entire development cycle, from functional analysis to on-site commissioning. This integrated engineering capability allows the company to address complex, high-requirement projects across demanding industries.

In the aerospace, Defence and space sectors, CILYX positions itself as a long-term technological partner for the development of customized industrial solutions, including:

- Test benches for components, equipment and subsystems (test cells, functional test equipment, instrumented skids, mobile test units, qualification means).
- Production equipment and assembly systems designed for regulated or mission-critical environments.
- Advanced automation and digitalization solutions, including robotics, vision systems, smart process monitoring, Industry 4.0 and ESG-aligned industrial solutions.

CILYX also has a proven ability to design, develop, qualify and integrate technological subsystems manufactured in small or medium series, delivered build-to-spec or co-developed with the customer's technical teams. This capability is frequently highlighted in collaborations with aerospace and Defence partners. With its own assembly workshops, CILYX ensures full control over execution, quality, confidentiality and responsiveness. The company also manages all project phases: requirement management, risk analysis, qualification, documentation, integration and after-sales support.

Operating across multiple industries – aerospace & space, Defence & security, pharma & biotech, energy, transportation, manufacturing and recycling – CILYX is recognized for its ability to transform complex requirements into robust, reliable and scalable industrial solutions.



## HEAD OFFICE

Rue des Entrepreneurs 10  
5020 Namur

## CONTACT PERSON

**Didier Granville**  
Senior Business Developer

## CONTACT DETAILS

+32 479 333 064  
Public@coexdyn.com

**Founded in 2019, Coexpair Dynamics offers services and machines to support its customers in the development of new aircraft structural composite parts based on Automated Fiber Placement equipment's.**

This includes the manufacturing of demonstrators and first parts prototypes in its Belgian facility (no serial production). Once the development is completed, Coexpair Dynamics extends its offer to the design and assembly of Automatic Fiber Placement Machines needed in its customer factory for the part production and based on Trelleborg Sealing Solution Albany (formerly named Automated Dynamics) technology.

Coexpair Dynamics aims to become a global leader in Automated Fiber Placement Machines and R&D in composite structure manufacturing. The company has a wide range of placement heads (from 4 to 12 tows and from 3 mm to 7.6 mm in width), gas torch, laser and pulsed light heating systems, a varied range of gantries and robots, complemented by rotary axes and Finite Element numerical simulation capabilities of the manufacturing process. Coexpair Dynamics is also working on the automation of thermoplastic compression molding and thermoset manufacturing with Coexpair's RTM/SQRTM closed molding industrial solutions well known in ASD Industry for the automation of the manufacturing of high-performance structural composites.

**Specific competences:**

**Automated Fiber Placement Composites Manufacturing Solutions**

SME

# Constellr Belgium S.A.

SECTORS



LC

# CPP

SECTORS



**constellr: Defence-Grade Thermal Intelligence for Sovereign Resilience.**

**Constellr provides a critical «behavioral layer» of Earth observation, enabling Defence and security forces to monitor activity where optical and radar sensors reach their limits. As the only EU-based provider of high-resolution thermal infrared (TIR) data, we deliver a physics-based signal that is nearly impossible to conceal or manipulate.**

Our satellite constellation, featuring the SkyBee platforms, provides 24/7 monitoring, capturing thermal signatures that reveal the functional status of assets rather than just their visual appearance.

Key Defence Capabilities:

Persistent Maritime Awareness: Detect vessel wakes and subsurface signatures, even at night or in low visibility.

Infrastructure Monitoring: Identify operational changes in missile fuel depots, covert manufacturing sites, and energy grids.

Strategic Intelligence: Corroborate OSINT by detecting heat signatures from active reactors and logistical hubs.

Early Warning: Uncover hidden operations and anticipate deployments through subtle temperature anomalies.

constellr ensures secure, sovereign control over intelligence data, strengthening European resilience and tactical deterrence.



**Consolidated Precision Products Belgium is a leading supplier to the aerospace industry, supporting helicopter, missile, and aircraft engine programs.**

Part of CPP Corporation, it operates within a global network of +20 casting facilities in the USA and Mexico, producing aluminum, magnesium, and superalloy components. Its subsidiary, CPP-Slovakia, enables cost-efficient manufacturing.

The company specializes in complex components made from advanced alloys, meeting high customer expectations in a fast-changing environment. It supplies critical parts that keep aircraft operating across aerospace and Defence sectors.

CPP delivers a full range of hot gas path components, including DS, single-crystal, and equiaxed blades, vanes, and structural castings, along with post-cast services. Certified to NADCAP and EN 9100:2009, it ensures quality, reliability, and performance.

HEAD OFFICE

Rue des Chasseurs-Ardennais 6  
4031 Liège

CONTACT PERSON

**Simon Casey**  
Business Development Manager

CONTACT DETAILS

+32 456 65 31 67  
simon.casey@constellr.com

<http://www.cppcorp.com>

HEAD OFFICE

P.I Hauts-Sarts 1e Avenue, 86  
4040 Herstal

CONTACT PERSON

**Xavier Delandshere**  
General Manager  
CPP Belgium / Slovakia

CONTACT DETAILS

+32 4 248 50 50  
xavier.delandshere@cppcorp.com

<http://www.cppcorp.com>

SME

# Dardenne

SECTORS



LC

# Decube Group

SECTORS



Established in 1978, Dardenne S.A. is experienced in built-to-print manufacturing of any high precision part or assembly for Aero, Space or Defence industry.

Its organization and size delivers optimum Quality-to-Agility ratio.

Equipped with all the machining technologies, Dardenne is able to manufacture any complex part, sub-assembly or assembly with the highest quality standard.

#### HEAD OFFICE

Prolongement de l'Abbaye 60  
4040 Herstal

#### CONTACT PERSON

**Benjamin Colas**  
Managing Director

#### CONTACT DETAILS

+32 4 295 57 00  
info@dardenne-meca.com

**Specific competence:  
Machining**

[www.dardenne-meca.com](http://www.dardenne-meca.com)



Decube Group is a Belgian multi-technical industrial group combining engineering, civil works, industrial coating, composite manufacturing and difficult-access operations.

#### Complementary Coating Workshops

Belgium Coatings and Monnaie S.A. operates 20,000 m<sup>2</sup> facilities, including a dedicated High Finition workshop meeting stringent quality and traceability standards, as well as an infrastructure dedicated to heavy-duty industrial painting and treatments.

Together, they offer complementary, scalable coating and surface-treatment solutions for vehicles, steel structures and strategic equipment.

Plasturgie Lazzerini manufactures custom fiberglass-reinforced polyester parts and polyurethane components, already serving transport and demanding industrial sectors. On-Site Industrial Expertise (Infrastructure, Access & Engineering)

Monnaie's Construction Department provides on-site surface treatments, abrasive blasting and high-performance anti-corrosion coating systems in sensitive, regulated and/or restricted environments. They also install industrial flooring systems, perform finishing works, and undertake small-scale maintenance operations.

Maclot-GC & Decubel – foundations, concrete rehabilitation and strategic infrastructure works.

Decube Consult – engineering studies and technical project management (Currently working for NATO).

Travhydro/Debiwork & ProAccess – scaffolding, containment systems and rope-access solutions for secure interventions in complex or restricted environments.

Through its subsidiaries, Decube Group offers an integrated, flexible and reliable industrial ecosystem capable of supporting Defence infrastructure, equipment maintenance and specialized technical operations.

#### HEAD OFFICE

Quai du Pont Canal 3  
7710 Strépy-Bracquegnies

#### CONTACT PERSON

**Charline Stevanoni**  
Projet Engineer R&D

#### CONTACT DETAILS

+32 64 46 02 60  
c.stevanoni@decube.be

[www.decube.be](http://www.decube.be)

SME

# DefenceWise

SECTORS



LC

# Dekimo

SECTORS



**DefenceWise® is a consultancy firm supporting the Defence and dual-use industries with their regulatory and compliance challenges, particularly export control.**

We provide legal and technical expertise in product classification, licensing and authorization regimes, and compliance requirements or exemptions linked to market entry (e.g. transport, marking, IP, ESG).

We develop Internal Compliance Programs, audit existing frameworks and provide remediation guidance. We offer a niche pragmatic approach tailored to each organization's maturity, value chain and strategic ambitions.

We strengthen resilience and strategic autonomy by helping with EU financing tools (autonomy guarantee) and extraterritorial risks (U.S. ITAR/EAR), while strengthening internal capabilities through innovative and engaging training (Escape Game Export Control) and practical operational tools.

HEAD OFFICE

Rue Delvaux 21  
4340 Othée

CONTACT PERSON

**Charlotte Villatte  
& Fabio Ferretti di Castelferretto**  
Co-founders  
& Managing Directors

CONTACT DETAILS

+32 4 277 02 22  
info@Defence-wise.com



**Dekimo, a belgian owned group, is the one-stop shop for all your developments in electronics and software.**

Electronics development :  
hardware and software embedded, design, layout

Prototyping and testing + product design

We can do the whole development of a device or work together with your R&D department for a specific expertise : directly or by the participation in a funded R&D consortium.  
Production en assembly

Consultancy :  
electronics, IT, IoT, QA, automation, cyber security

HEAD OFFICE

Rue Laid Burnait 6  
1348 Louvain-la-Neuve

CONTACT PERSON

**Didier Miller**  
Business development manager

CONTACT DETAILS

+32 10 39 20 90  
didier.miller@dekimo.com

SME

# Deltatec

SECTORS



SME

# Dumoulin Aero

SECTORS



**DELTA TEC** provides electronic design services to clients across a wide range of industries, with expertise in high-reliability hardware, software, FPGA, and edge AI. The company focuses on understanding customer needs and delivering efficient, high-quality solutions, while keeping development cycles short.

HEAD OFFICE

Rue Gilles Magnée 92/6  
4430 Ans

CONTACT PERSON

**Eric CALLUT**  
Business Developer

CONTACT DETAILS

0032 4 239 78 80  
contact@deltatec.be

Its designs are tailored for both harsh and constrained environments. DELTA TEC also offers manufacturing capabilities, enabling a complete end-to-end approach from concept to production.

Notably, DELTA TEC designs systems enabling secure communications across multiple networks, ensuring strict isolation between security levels and preventing any data leakage between domains.

By working closely with partners, the company stays aligned with the latest technological standards and ensures long-term support. DELTA TEC is also part of the Mine Counter Measures (MCM) Laboratory, contributing to the development of innovative solutions for Defence and maritime applications.

[www.deltatec.be](http://www.deltatec.be)



**Dumoulin Aero – MB Industries Holding**  
Dumoulin Aero is a trusted partner for the manufacture of high-precision machined parts and assemblies for aerospace and Defence applications. Certified EN/AS 9100, the company specializes in serial production of complex components, ensuring consistent quality, full traceability and reliable on-time delivery.

HEAD OFFICE

Rue Al'Trappe 110  
4432 Alleur

CONTACT PERSON

**Gaël QUETTIER**  
Managing Director

CONTACT DETAILS

+32 4 228 89 60  
management@dumoulin-aero.com

Within military programs, Dumoulin Aero contributes to major aircraft platforms such as the Airbus A400M and A330 MRTT, as well as the Embraer C-390, supporting leading OEMs and tier-1 suppliers with robust industrial capabilities and a strong quality culture.

As part of the Mechanical Division of MB Industries Holding, Dumoulin Aero operates in close synergy with its sister companies to provide an extended Defence manufacturing ecosystem. Menendez Mecanique delivers flexible machining solutions for small to medium series and complex Defence components, while La Nitruration Moderne offers advanced surface treatments to enhance durability of critical parts.

This integrated approach allows the group to support Defence customers across the full value chain – from precision machining to specialized surface treatment – combining industrial performance, agility and long-term partnership. Based in Belgium and at the heart of the European aerospace and Defence network, Dumoulin Aero and its partners are committed to meeting the highest standards of quality, reliability and operational excellence for mission-critical applications.

[www.dumoulin-aero.com](http://www.dumoulin-aero.com)

SME

# Dynali

SECTORS



SME

# Eliosys

SECTORS



Dynali Helicopter Company is a manufacturer of ultralight helicopters and related aerial solutions. The company has taken the market leadership of ultralight helicopters (ULH). Its current best-seller is the two-seater H3 Sport (MTOW 530 kg) known for its excellent flying capabilities and low operating costs.

#### HEAD OFFICE

Avenue Thomas Edison 101  
1402 Thines (Nivelles)

#### CONTACT PERSON

**Francis Huchette**  
Head of R&D Department

#### CONTACT DETAILS

+32 67 55 29 98  
info@dynali.com

Dynali designs, manufactures and assembles helicopters and UAVs for private users, flight schools and industrial companies.

The Helicopter Division is focused on leisure helicopters. With specialists in machining, welding, painting, engine preparation and avionics, Dynali controls the whole production process which ensures high quality and short lead times.

Within the Aerial Solutions Division, Dynali provides utility helicopters and UAV platforms. The high-payload platforms are dedicated to various applications such as territory surveillance, maritime search & rescue, agriculture and logistics. The engineering team develops solutions based on client requirements and manages systems integration.

Dynali is already collaborating with major international partners who are flying fully autonomous UAVs. It is the only company to provide platforms with a maximum payload of 230 kg, an autonomy of 8-10 hours and flying up to 10,000 feet.

[www.dynali.com](http://www.dynali.com)



#### HEAD OFFICE

Quartier Polytech 2 Rue des Poles 1  
4000 Liège

#### CONTACT PERSON

**DI SIMONE Cadia**  
Assistante commerciale

#### CONTACT DETAILS

+32 4 361 59 07  
sales@eliosys.eu

[www.eliosys.eu](http://www.eliosys.eu)

Founded 15 years ago and based in Sart Tilman, Belgium, ELIOSYS is a public limited company that has rapidly established itself as a leader in the field of photovoltaics, contributing to the transformation of the renewable energy sector.

ELIOSYS has raised its standards to ISO 17025 accreditation, making it one of the few laboratories in the world to specialise in photovoltaics at this level. Our main activity is to carry out tests on photovoltaic modules in our laboratory and to issue certificates of conformity.

In addition to our expertise in this field, we also offer support services to sectors such as construction, defence and power electronics.

We also have a support office for companies involved in special energy projects that combine various innovative techniques to optimise performance and sustainability.

# Eurenco Clermont

SECTORS



# EHP (Euro Heat Pipes)

SECTORS



Eurenco Clermont is a manufacturer of propellant powder for small caliber ammunition (less than 20mm), and other energetic raw materials for the large caliber propellant sector.

The doctorate-qualified R&D team work proactively on various research projects concerning new energetic materials, matrices for additive manufacturing, hypervelocity, modelling, with thermodynamics and kinetics calculations, and many other research projects.

We regularly prepare patents and publications in state-of-the-art topics, and collaborate with many, mainly European, universities, research centres, MoDs and companies.

#### HEAD OFFICE

176 rue de Clermont  
4480 Engis

#### CONTACT PERSON

**Rowan Dobson**  
Project coordinator and adviser  
for energetic materials

#### CONTACT DETAILS

+32 4 273 82 90  
r.dobson@eurenco.com



EHP is a recognized player in the Defence sector, thanks in particular to its skills in the development and manufacture of advanced space/launch vehicle solutions with thermal, mechanical and propulsion functions.

Our expertise in space systems has enabled us to make an active contribution to numerous Defence-related programs, notably for observation missions, such as the supply of thermal control subsystems for the focal plane of CSO satellites. In addition to observation missions, EHP is also active in Defence missions for telecommunications (Spain-sat NG, SDA, etc.) and SSA (SDA, etc.) applications. EHP is also active in the launcher market (thermal control of electronic units in the upper stage of the launcher) and aims to implement its thermal control solutions in the new generation of UAVs.

In addition, EHP is highly vertically integrated, integrating no ITAR components into its products, and has an entirely Western supply chain, which limits its dependence on non-European players.

By developing solutions at the cutting edge of technology, we are pursuing our commitment to serving Defence in an increasingly complex geopolitical environment.

#### HEAD OFFICE

9 rue de la Science  
1400 Nivelles

#### CONTACT PERSON

**Maxime Boninsegna**  
Business development manager

#### CONTACT DETAILS

+32 67 88 94 94  
sales@ehp.space

#### Specific competences:

**Fluid, Thermal, Mechanical & Thermal tests services, Engineering, large X-ray bunker**

SME

# Euresys

SECTORS



SME

# European Metrology Systems (EMS)

SECTORS



**Euresys is a leading and innovative high-tech company, designer and provider of image and video acquisition components, frame grabbers, image analysis software and FPGA IP Cores. Euresys is active in computer vision, machine vision, factory automation and medical imaging.**

The company's image acquisition expertise covers analog and digital video acquisition, FPGA programming, high-frequency electronics, video compression and camera control. Our software image analysis expertise includes 3D inspection, defect detection using deep learning, sub-pixel measurement, pattern matching, color analysis, optical character recognition, barcode reading and verification.

Sensor to Image, a subsidiary of Euresys, is a machine vision specialist developing and providing FPGA based imaging and video IP Cores. Its expertise encompasses the GigE Vision, CoaXPress, USB3 Vision, MIPI and GenICam standards. Sensor to Image also offers custom designs (development of custom video processing platforms based on FPGA) and prototypes or series production of the developed hardware. Customers will benefit from design and production on the same site from a single source with the several benefits: early-stage layout-optimization for cost optimization, fault prevention during PCB design, reduction of data transfer issues, faster time-to-market and MIL standard capabilities.

#### HEAD OFFICE

Rue du Bois Saint-Jean 20  
4102 Seraing

#### CONTACT PERSON

**Sébastien Granatelli**  
Sales Manager Europe

#### CONTACT DETAILS

sales.europe@euresys.com

[www.euresys.com](http://www.euresys.com)



#### HEAD OFFICE

Rue de l'Eperonnerie 2  
4041 Milmort

#### CONTACT PERSON

**Salvatore Cupelli**  
Director

#### CONTACT DETAILS

+32 4 228 04 07  
info@ems.be

[www.ems-benelux.com](http://www.ems-benelux.com)

#### Leader in Metrology.

The combination of our many years of experience and our know-how mean that for each of your applications we are able to offer you a tailor-made solution.

Alongside this wide range of measurement solutions, our range of services completes our offer and allows us to offer you a global solution. Indeed, our services can support you throughout the life of your investment.

It is through these services and our approach focused on your needs that we want to make a difference!

**Specific competence:  
Metrology.**

SME

# Exail Robotics Belgium

SECTORS



SME

# Sub-Alliance Feronyl

SECTORS



Exail Robotics Belgium is a pioneering company specializing in cutting-edge maritime robotics, with a strong focus on mine countermeasure (MCM) systems. As part of the Exail Group, the company plays a crucial role in the European Defence and security landscape, delivering innovative unmanned maritime solutions to enhance naval operations.

With a dedicated serial production facility for maritime drones, Exail Robotics Belgium ensures the manufacturing of high-performance autonomous systems designed to operate in complex and challenging environments. These advanced robotic technologies help naval forces conduct safer, more efficient, and cost-effective missions while minimizing human risk in mine warfare operations.

Committed to technological excellence and operational reliability, Exail Robotics Belgium collaborates with international Defence partners to develop next-generation robotic solutions that meet the evolving needs of modern naval forces.

#### HEAD OFFICE

Rue de l'Echauffourée 1  
7700 Mouscron

#### CONTACT PERSON

**Gregory Leclercq**  
Business Developer

#### CONTACT DETAILS

+32 59 25 24 00  
gregory.leclercq@exail.com

[www.exail.com](http://www.exail.com)



Since 1950, SUB-ALLIANCE|FERONYL is the leader in the production of advanced mechanical systems out of multi-materials : polymers, metallic alloys, ceramics (UHTC) and composites.

SUB-ALLIANCE combines the expertise of 4 manufacturing divisions, spread over 7 production sites. Each division is specialized in the development, prototyping, production and assembly of composite, polymer and metal parts. Equipped with state of the art equipment, we enable the production of gears, shafts, couplings and geared parts for various aircrafts as well as soft and hard metal machining up to 2600mm.

We produce the most complex parts for the Defence industries and develop materials that will contribute to the advancement of hypersonic technology.

We've extensive references in the Defence market: F-35 Belgian Program / MCMV / Ammunition 20 to 105mm / Armored components for weapon systems/ transmissions for NH90, TTH and H145 / Command systems for air- and land systems / UHTC Material for Aerospace & Hypersonic / Composite panels & Geared parts for aircrafts

#### HEAD OFFICE

Boulevard Industriel 101  
7700 Mouscron

#### CONTACT PERSON

**Charles-Edouard DENDONCKER**  
Deputy CEO

#### CONTACT DETAILS

+32 56 85 75 30  
feronyl@feronyl.com

[www.feronyl.com](http://www.feronyl.com)

SME

# Filame

SECTORS



LC

# FN Browning Group

SECTORS



Filame Brussels SA

## HEAD OFFICE

Avenue Robert Schuman 121  
1401 Nivelles

## CONTACT PERSON

**Jean Gabriel**  
CEO/Managing Director

## CONTACT DETAILS

+32 67 550 600  
jgabriel@filame.com

**Filame is a manufacturer of high-tech wire and sheet metal works. From individual parts to large series, we manufacture springs and wire forms, cutting parts and stamping, sheet metal works and welding.**

We manufacture all kind of wire springs (compression, tension, torsion) and formed wire from 0,1 mm to 20 mm in all kind of materials (spring steel or steel, spring stainless steel (302- 316- 316L, 17-7PH, duplex, ...) or stainless steel 304, Inconel 600 - 718 - 750, Nimonic 90, Elgiloy, Hastelloy; Bronze, CuSN6, CuBe, ...).

We also manufacture all kind of metal parts, spring plate out of metal sheets and coils on mechanical presses or automatic presses with multistep toolings as well as with laser cutting, forming, stamping and welding.

Thickness of the material ranges from 0,1 mm to 10 mm. We also made small sub-assemblies. We use all kind of material whether spring material or not (steel, stainless steel, special alloys like Inconel, Nimonic, ...) and copper based material. All our toolings are made in our own tooling department. Our Engineering Department can assist you in all your conception, design and design for manufacturing.

Within our Engineering Department we also have a prototyping department which can prototypes for you all your parts. Beside the Defence Industry we work for several other industries among which Automobile, Machine Manufacturers, Civil engineering machines, Locksmith, Aerospace, ...

[www.filame.com](http://www.filame.com)



## HEAD OFFICE

Voie de Liège 33  
4040 Herstal

## CONTACT PERSON

**Henry de Harenne**  
Head of Communications

## CONTACT DETAILS

+32 4 240 89 11  
info@fnbrowninggroup.com

[www.fnbrowninggroup.com](http://www.fnbrowninggroup.com)

**FN Browning Group markets world-leading brands: FN, Browning, Winchester and Noptel.**

Recognised worldwide for innovation and dependability, their products and services equip the most demanding defence institutions, law enforcement authorities and responsible firearm owners and hunters.

Headquartered in Herstal, FN Browning Group employs more than 3,000 people through its subsidiaries in Belgium, the USA, Portugal, the UK and Finland.

SME

# Global Design Technology (GDTech)

SECTORS



SME

# Genitek Engineering

SECTORS



#### HEAD OFFICE

Avenue de l'expansion 7  
4432 Alleur

#### CONTACT PERSON

**Joseph Marra**  
Chief Business Development Officer

#### CONTACT DETAILS

+32 479 43 04 59  
Joseph.Marra@gdtech.eu

GDTech is a team of approximately 250 engineering professionals delivering advanced engineering and simulation services across all defence domains, including Land, Air, Sea, Space, and Drone and Counter Drone systems.

The company provides expertise in CAD design, finite element analysis (static and dynamic), computational fluid dynamics (CFD), and system modelling, supporting product development from early concept to prototype.

GDTech has strong experience in analysing defence systems under extreme conditions such as impact, explosion, fragmentation, and underwater blast. The team also performs advanced trajectory simulations for projectiles and rockets, including high speed and hypersonic regimes.

Additional capabilities include survivability assessments, digital twin development, acoustic and optical analysis, radar cross section (RCS) calculations, and AI based modelling and optimisation to improve system performance, detection, and design.

GDTech actively participates in regional and European R&D programmes, including projects funded by the European Defence Fund (EDF). Within the GARUDA project, GDTech develops reduced order numerical models (digital twins) to rapidly assess the aerodynamic and structural performance of next generation drones and performs preliminary sizing of selected concepts. The company also designs digital twins for predictive maintenance applications.

[www.gdtech.eu](http://www.gdtech.eu)



#### HEAD OFFICE

Rue Edouard Belin 5  
1435 Mont-Saint-Guibert

#### CONTACT PERSON

**Christian Lambricht**  
CEO

#### CONTACT DETAILS

+32 10 460 250  
sales@genitek.be

[www.genitek.be](http://www.genitek.be)

Genitek Engineering is a high-end engineering company based in Belgium with expertise on mecatronic, low-level software, FPGA, certification, and testing, obsolescence management, among others.

We are specialised in the development of embedded electronic systems in the Defence and aeronautical sectors.

We help our clients find optimum solutions, from product specification to testing, certification and production.

# Global Mobile Lab (GML)

SECTORS



## HEAD OFFICE

Place du Marché, 12  
6870 Saint-Hubert

## CONTACT PERSON

**Marc de la Brassinne**  
Chief Executive Officer

## CONTACT DETAILS

+32 477 370 127  
info@globalmobilelab.com

- Innovative solutions to fight infectious diseases,
- Real time diagnostic and reporting to cut the transmission chain of epidemics.

GML is a commercial spin-off of the successful B-LiFE (Biological Light Fieldable Laboratory for Emergencies) operational service supported by ESA.

Proven track record in addressing health crises, Ebola mission in Guinea, Covid 19 mission in Italy.

GML is unique in combining Mobile Biological Laboratories with space-based applications, integrated satellite telecommunication systems and satellite imagery for real time epidemiological mapping service.

GML Glovebox BSL-3 (Bio Safety Level 3) environment enables rapid field diagnostic of dangerous infectious diseases.

GML is providing training of the Medical Staff of the users with a University Reference Laboratory.

# GROUPEMECA (Vanhulen)

SECTORS



## HEAD OFFICE

Prolongement de l'Abbaye 86  
ZI des Hauts Sarts-Zone 1  
4040 Herstal

## CONTACT PERSON

**Pierre Schaaps**  
Sales Manager

## CONTACT DETAILS

+32 42 899 999  
info@vanhulen.be

GROUPEMECA is active in the civil and military aerospace, electro-technical equipment, nuclear, Defence, office automation, automotive, electro domestics, medical and construction technology industries.

GROUPEMECA's production fleet counts + 300 machines, with unrivalled performance and outstanding reliability. The raw materials processed are carbon steel, stainless steel, non-ferrous metals and special alloys.

GROUPEMECA carries out required surface- and finishing treatments, including heat treatment in pulsed air furnaces or under controlled atmosphere (vacuum) and penetrant inspection.

## Major Products / Services:

Compression, extension, torsion, double torsion springs. Bended wire. Induction coils. Leaf springs and stamped parts. Fragmentation body for grenade, mortar and rockets. Assembly of metal parts and plastic parts. Welding TIG-MIG-Laser. Surface treatments.

# Hexcel Composites

SECTORS



# High-Tech Plastics Europe

SECTORS



Hexcel's plant was established in Welkenraedt in 1967.

Welkenraedt is Hexcel's European center of excellence for Engineered Core, the name we give to our processed honeycomb parts that are machined and finished in a number of ways and then supplied as ready to fit «drop-in» parts to customers.

Key applications for products made at Hexcel's Welkenraedt plant are aerospace structures - for civil and Defence aircraft, helicopters and aero-engines.

#### HEAD OFFICE

Rue Trois Bourdons 54  
4840 Welkenraedt

#### CONTACT PERSON

**Morad El Abbadi**  
Plant Manager

#### CONTACT DETAILS

+32 87 30 74 11  
morad.elabbadi@hexcel.com



#### HEAD OFFICE

Rue de la Barrière de Fer 38  
7711 Dottignies

#### CONTACT PERSON

**Geoffrey Ducrocq**  
Directeur adjoint

#### CONTACT DETAILS

+32 56 58 88 93  
geoffrey.ducrocq@htp-europe.com

Established in 1954, High-Tech Plastics Europe is the partner dedicated to the manufacturing of High-Tech thermoplastics and composite parts.

Under EN9100 certification and in ISO8 clean environment we can manage the total manufacturing of projects including parts in PEEK, PPS, PEI, PAA,.... and all other technical raw materials filled with glass and carbon fiber on machines from 50 Tons up to 500 Tons all fitted with robots.

Our expertise in injection tools and in injection moulding is recognized by many partners that also appreciate our competences in ultrasonic welding of parts and components.

Focused first on the quality and the professionalism of our deliveries, all attention is given to controls in production and respect of the delivery time.

The complete follow-up of the project starting from 3D printing until validation is completely managed by our team in order to reduce the industrialization time of your developments while maintaining confidentiality in the management of data's.

Furthermore, we try to minimize our impact on the environment and our carbon footprint thanks to several integrated measures.

OTHER

# ID2MOVE

SECTORS



SME

# IONICS

SECTORS



**ID2Move is a center of excellence on unmanned autonomous systems & drones (ground -UGV-, air -UAV-, water -UMV-) with the most equipped and diversified indoor/outdoor test zones in Europe. We are based in Nivelles, Belgium.**

**HEAD OFFICE**

Rue de l'Industrie 20  
1400 Nivelles

**CONTACT PERSON**

**Emilien Watelet**  
Director

**CONTACT DETAILS**

+32 4 72 88 02 91  
emilien.watelet@id2move.eu

In our restricted zone (EBR 67) you can fly over agricultural, urban and industrial areas, speedways, railway tracks, forests, quarries and a Defence-dedicated area.

An outdoor racing track is available for autonomous land vehicles. The indoor test zone measures 670m<sup>2</sup> and is 8m high fully equipped with motion capture cameras and removable floor. An indoor pool and a former stone quarry (50m deep) are available for aquatic drones.

We also offer working spaces (offices, coworking, meeting rooms), technical and business coaching, prototyping lab, university support, networking events, certification, homologation, clearance, and international network.



**Founded in 2014, IONICS develops and supplies surface treatment technologies and processes: electroplating, plasmasputtering (PVD, PeCVD) and ion implantation. Our customers capitalize on our innovative approach and responsive services as equipment supplier and as job coater.**

**HEAD OFFICE**

Rue des Alouettes 1  
4042 Liers

**CONTACT PERSON**

**Aida NASIRI**  
Chief Operating Officer

**CONTACT DETAILS**

+32 4 278 91 60  
info@ionics-group.com

Combining job coating capabilities with the design and construction of equipment, IONICS offers customers end-to-end solutions, from validation prototypes and pre-industrial lines to full-scale production lines.

With a broad range of applications, IONICS operates across multiple sectors, including Defence, automotive connectors, architectural glass, biomedical devices, machining tools, powder-based applications, luxury goods, and more.

With around 17 employees, IONICS operates across four sites: three in Belgium, located in Liers, Herstal, and Mons, and one in France, in Canouville.

# Industrial Construction and Automation (ICA)

SECTORS



ICA is a Belgian industrial automation company specialized in custom machines, retrofit projects and industrial services for demanding production environments. With its multidisciplinary engineering office and in-house workshop, ICA supports customers from design to commissioning, maintenance and technical support.

#### HEAD OFFICE

Avenue Zénobe Gramme, 26  
1300 Wavre

#### CONTACT PERSON

**Antoine Dobbels**  
CEO

#### CONTACT DETAILS

+32 10 40 14 18  
antoine@ica.be

Its activities are structured around the following areas of expertise:

#### STUDIES, DESIGN & PROJECT MANAGEMENT

ICA combines mechanical engineering, electrical design, automation, robotics and industrial vision to support projects from feasibility studies to commissioning and after-sales support.

#### CUSTOM MACHINES & INDUSTRIAL EQUIPMENT

ICA designs and builds custom machines, assembly systems, test benches and industrial equipment adapted to customer processes and constraints.

#### RETROFITTING & SECURING

ICA modernizes production equipment through retrofit engineering, automation upgrades and machine securing projects, including CE compliance and safety improvements.

#### CONTRACT MANUFACTURING & MAINTENANCE SERVICES

ICA also provides industrial assembly, electrical cabinet manufacturing, subcontracted machine integration and maintenance services.

#### ECO-DESIGN, SAFETY & INDUSTRIAL STANDARDS

ICA integrates eco-design, safety requirements and industrial standards to improve durability, reduce resource consumption and ensure compliance with CE, ATEX and VCA practices.

#### Specific competences:

**Customized Automated Machines**  
**Line upgrade to CE standards**  
**Maintenance**

[www.ica.be](http://www.ica.be)

# Innovative Coating Solutions

SECTORS



ICS is specialized in the deposition of Thin Films by Physical Vapor Deposition (PVD), film characterization and simulation of thin film growth.

ICS business is organized around 4 pillars:

- Job Coater: parts are coated with one of ICS's recipes, based on the customers' needs.
- R&D Consulting in Coating: ICS develops tailor-made coatings to answer the customers' requests.
- Licensing: ICS sells licence processes in customers' machines or installs and integrates a dedicated machine in the customers' production facility.
- Simulation: ICS provides services and sells software for processing and film growth modelling, as well as anomalies detection and product properties based on AI.

In relation with Defence, ICS has developed solutions to coat highly energetic powder: we improve the efficiency of thermite and propellants by protecting them from oxidation, increasing their performances, and enhancing lifetime.

#### HEAD OFFICE

Rue Jean Sonet 10  
5032 ISNES

#### CONTACT PERSON

**Alexia PETIT**  
Executive Secretary

#### CONTACT DETAILS

+32 473 55 77 30  
admin@incosol4u.com

#### Specific competences:

**Thin film deposition and simulation of optical properties**

[www.incosol4u.com](http://www.incosol4u.com)



Isomatex develops **TENRON®**, a high-performance mineral material designed to meet the requirements of the most advanced protection applications.

Thanks to its mechanical strength, energy absorption capacity, and excellent weight-to-performance ratio, TENRON® provides an effective response to impacts and extreme stresses. Its fire resistance, as well as its stability in aggressive environments, make it a reliable and durable solution for systems exposed to severe conditions.

#### Defence / Dual-use Positioning

With TENRON®, Isomatex addresses the needs of the most demanding Defence and dual-use sectors. Its advanced properties, particularly in terms of ballistic protection, thermal resistance, and energy dissipation, make it possible to protect both people and equipment in critical environments. This dual-use positioning opens the way to high value-added applications, both for Defence forces and sensitive civilian industries, contributing to raising safety standards through an approach that is both high-performing and sustainable.

#### Main Applications

TENRON® stands out in contexts where safety and performance are critical. Integrated at the core of advanced protection solutions, it is used in sectors such as aerospace, automotive, maritime, etc., where mechanical, thermal, and environmental constraints are particularly high. Its ability to maintain its performance under extreme conditions (humidity, corrosion, or temperature variations) helps improve system reliability and durability, while supporting industries in moving toward more sustainable solutions.

#### HEAD OFFICE

Rue Camille Hubert 29  
5032 Gembloux (Isnes)

#### CONTACT PERSON

**Bernard Voss**  
Business Development Manager

#### CONTACT DETAILS

+32 8172 86 86  
bernard.voss@isomatex.com



#### HEAD OFFICE

Boulevard Initialis 28  
7000 Mons

#### CONTACT PERSON

**Lorenzo Bassani**  
CEO

#### CONTACT DETAILS

administrative@it-optics.com

IT-OPTICS s.a. is an IT services company, one of whose key focus areas is free software. Based in Mons, IT-OPTICS offers the experience and skills of its engineers, specialised in multiple domains such as the next, Windows, networks and databases to help its customers.

ITO aims to bring the IT infrastructure to its maximum operational level using the power of Free Software and GNU/Linux, without ignoring commercial and proprietary software. The company ITOPTICS is made up of around 10 engineers and has today become one of the key players in the Belgian OpenSource market. Over the past three years, the company has invested in working out dedicated solutions in the world of logistics. As well as the concept of IT services.

IT-OPTICS is the partner of choice in implementing EPC IS solutions, the exchange and sharing of information on a supply chain's logistics flows. The company relies on solid partnerships, embodied within the group by its major shareholder CEDREBEL, both in terms of R&D and its historic closeness to the Multitel research centre. Its skills are well fitted to the different tasks of development allowing to be compliant with GS1 standards.

SME

# JDC Innovation

SECTORS



LC

# John Cockerill

SECTORS



#### HEAD OFFICE

Rue de l'Expansion 29  
4460 Grâce-Hollogne

#### CONTACT PERSON

**Benoit Baudru**  
Commercial Manager

#### CONTACT DETAILS

+32 42 39 80 80  
info@jean-delcour.be

Our company delivers high-value expertise in connectivity, harnessing, and customized cabling solutions. We also specialize in the pre-wiring of electrical cabinets, pre-assembly of electrical and pneumatic enclosures, assembly of electronic boards and test bench racks, as well as welding, metal fabrication, and precision machining.

Leveraging this broad range of capabilities, we provide innovative, tailor-made solutions to demanding industries such as aeronautics, Defence, rail, and aerospace.

From build-to-print assembly using customer-supplied components to full-scale serial production, we support our clients at every stage of their projects. Our added value lies in our ability to go further—offering co-design and co-development services, along with comprehensive support in industrialization and the sourcing of raw materials and components.

Committed to excellence, our company is certified to EN9100, ISO 9001, ISO 14000, and ISO 45000 standards, ensuring the highest levels of quality, safety, and environmental responsibility.

[www.jean-delcour.be](http://www.jean-delcour.be)



#### HEAD OFFICE

Rue Alfred Deponthière 44  
4431 Ans

#### CONTACT PERSON

**Xavier Delhaye**  
Communication Manager

#### CONTACT DETAILS

+32 4 330 20 01  
Defence@johncockerill.com

[www.johncockerill.com](http://www.johncockerill.com)

Member of the bicentennial John Cockerill Group, John Cockerill Defence is the technological leader in multi-functional, high-effect turrets in the 25-120mm range for light and medium weight armored vehicles.

John Cockerill Defence develops and integrates complete and innovative solutions: design, production, integration and upgrade of weapons systems, operational and tactical training, Agueris® simulation systems (virtual immersive, mobile, embedded and inter-connectable), through-life support and innovative functionalities.

Marketed under the Cockerill® brand, John Cockerill Defence weapons systems combine superior firepower and light-weight for high-mobility armored vehicles, guaranteeing performance and protection.

# KNDS Belgium

SECTORS



# Lambda-X High Tech



## KNDS

KNDS SA is a Defence company based in Belgium specialized in the development and the production of weapon systems and a comprehensive range of medium and large caliber ammunition.

KNDS SA has been based in Belgium since 1938 and has built a world-wide reputation. KNDS Belgium is a wholly owned subsidiary of NEXTER SYSTEMS which is based in Versailles, FR.

KNDS SA supplies large and medium caliber ammunition to Defence establishments (including NATO) throughout the world.

### HEAD OFFICE

Rue Grinfaux 50  
7181 Petit-Roeulx-lez-Nivelles

### CONTACT PERSON

**Arnaud Le Grelle**  
Public Affairs Manager

### CONTACT DETAILS

arnaud.legrelle@knds.be

## LAMBDA-X HIGH-TECH INNOVATION

### HEAD OFFICE

Avenue Robert Schuman 102  
1401 Nivelles

### CONTACT PERSON

**Jean-Hervé Lecat**  
Business Development Manager  
Space & Defence

### CONTACT DETAILS

+32 6779 40 80  
jhlecat@lambda-x.com

Lambda-X High Tech is a Belgian company specializing in engineering services for the development of optical systems and subsystems for imaging and metrology applications. From the initial stages of conception to the final steps of industrialization, including prototyping and rigorous qualification, Lambda-X High Tech offers comprehensive and innovative custom-made solutions.

Based in Nivelles and certified ISO9001 and EN9100, the company boasts state-of-the-art facilities, including a 730 m<sup>2</sup> ISO 7 clean room, equipped with advanced alignment, assembly, and metrology tools, enabling Lambda-X to conduct high-level production and research activities for Space, Defence, LifeScience and Quality & Process Control applications.

Specific competence: Design, Manufacturing, Qualification and Validation of:

- Optical Payloads for Earth Observation (Visible, SWIR, LWIR)
- Optical Payloads for Space Situational Awareness (Visible, SWIR, LWIR)
- Guidance Optics
- Boresights

SME

# Lasea

SECTORS



SME

# MachineSight

SECTORS



**Experts in laser micromachining and microwelding, LASEA designs high-precision solutions for the most demanding applications in the Defence sector.**

Thanks to its femtosecond and picosecond laser technologies, LASEA enables the advanced functionalization of surfaces—hydrophobic, hydrophilic, stealthy, with high heat dissipation, or with optimized tribological properties—as well as the machining and welding of high-precision electronic and mechanical components.

Furthermore, LASEA develops pulsed laser effectors integrated into counter-drone systems (C UAS), dedicated to neutralizing swarms of short-range mini-drones.

#### HEAD OFFICE

Liege Science Park, Rue Louis Plescia 31  
4102 Seraing

#### CONTACT PERSON

**Pascal Durdu**  
Business Developer

#### CONTACT DETAILS

+32 4 365 02 43  
info@lasea.com

[www.lasea.com](http://www.lasea.com)



**MachineSight is a dynamic company made up of 25 passionate and dedicated professionals, specializing in the integration of customized automated and robotic equipment. Since our inception, we have distinguished ourselves by our ability to handle all project phases, from preliminary studies to on-site installation, including detailed studies, implementation, and system validation. Our versatile team possesses solid expertise in mechanics, industrial electricity, and software development, allowing us to provide complete and efficient solutions to our clients.**

#### HEAD OFFICE

Rue de la Croix Bande 7  
6900 Marloie (Marche-enFamenne)

#### CONTACT PERSON

**Jean-François AERNOUITS**  
Business Developer

#### CONTACT DETAILS

+32 84 45 60 08  
info@machinesight.eu

[www.machinesight.eu](http://www.machinesight.eu)

At the core of our offering, we have developed an innovative automated visual inspection solution called OcculusTM. With a meticulous selection of suitable cameras and lighting, OcculusTM can accurately detect manufacturing defects, scratches, marking imperfections, as well as metrology and cosmetic defects. This advanced technology ensures rigorous and reliable quality control, meeting our clients' high standards and ensuring flawless production.

Our main clients are in the pharmaceutical and aerospace sectors, where precision and reliability are crucial. We work closely with them to develop tailor-made solutions that meet their specific needs and optimize their production processes. Additionally, our achievements in these sectors strictly adhere to the regulatory framework associated with this demanding field. At MachineSight, we are committed to providing cutting-edge equipment and impeccable service, thus contributing to the success and competitiveness of our clients.

SME

# MEBF

SECTORS



SME

# Mecasoft

SECTORS



Located in Belgium, MEBF is a grouping of highly specialized industrial professionals in the manufacturing of firearm components, accessories, and supports.. It is their expertise, know-how, and perfect knowledge of the sector, recognized by major Belgian and multinational firearms manufacturers, that brought them together.

The MEBF grouping has a large production capacity with a complete machine park across two sites, totaling over 10,000 square meters of facilities. In perfect complementarity, the grouping takes care of technical projects and the production of critical firearm parts in small and medium series, ranging from 1 to 100,000 pieces, as well as assemblies and even prototypes, thanks to its integrated technical office. MEBF holds an arms export license.

#### HEAD OFFICE

haute Marexhe, 176  
4040 Herstal

#### CONTACT PERSON

**Gregory PELZER**  
CEO

#### CONTACT DETAILS

+32 473 63 60 98  
gregory.pelzer@mebf.be

[www.mebf.be](http://www.mebf.be)



**Machining aerospace and Defence precision components, from prototyping to series production, for more than 40 years.**

We support OEMs and Tier-1 manufacturers involved in major programs such as A320/A350, A400M or F-16 for industrial leaders like Safran, Sonaca, Sabca, FN, John Cockerill, Thales, EHP and Von Karman, from classic programs to advanced developments including weight reduction, high-temperature resistance, miniaturization, heat pipes and micro tubes for sensors.

Our expertise and know-how is dedicated to the most demanding precision industries – aerospace, Defence, instrumentation, medical and pharmaceutical. We leverage a broad range of high-precision machining technologies and operate state-of-the-art quality control systems. Our processes are certified to EN9100:2016 standards and Mecasoft is accredited to Safran DMP 66 and Airbus AIPS 03-09-004 for metals machining.

We are fully committed to delivering a reliable and robust supply chain. As a local SME partner, we stand for agility, responsiveness, and built-in redundancy.

#### HEAD OFFICE

Rue de la Molinee 60  
5537 Anhee

#### CONTACT PERSON

**Daniel Kedzierski**  
Commercial Director

#### CONTACT DETAILS

+32 82 611 612  
contact@mecasoft.be

[www.mecasoft.be](http://www.mecasoft.be)

SME

# Mockel

SECTORS



SME

# M3 Systems Belgium

SECTORS



**Mockel SA is characterised by a young, committed team whose expertise lies in high-precision mechanics. The East Belgian family business supplies system suppliers in the aerospace, defence and mechanical engineering industries throughout Europe.**

In addition to ISO 9001 and EN 9100, the latest ISO 14001 certification demonstrates the company's commitment to sustainability, while the focus remains on the needs of its customers. At the beginning of 2024, Mockel was honoured with the Factory of the Future Award. Behind all this are 45 specialised professionals who shape the future every day.

#### HEAD OFFICE

Rue du Développement 9  
4837 Baelen

#### CONTACT PERSON

**LECOQ Antoine**  
CO-CEO

#### CONTACT DETAILS

+32 87 59 39 59  
info@mockel-precision.be

**Specific competence:**  
**Production of precision components**

[www.mockel-precision.be](http://www.mockel-precision.be)



**M3 Systems is a 20 years old SME specialised in GNSS and radio-navigation.**

M3 Systems has developed a portfolio of GNSS test platform to support GNSS developers all along the development chain with simulation, record/replay, vulnerability dedicated tests.... M3 Systems has also developed PNT solutions relying on the fusion of GNSS data with other positioning sensors data (such as Inertial Measurement Units, Odometry, Barometer....). M3 Systems also supports its sister company that manufactures long endurance (up to 1000 km distance) fixed-wing UAV, with positioning and navigation expertise and solutions.

#### HEAD OFFICE

Chemin du Stocquoy 1  
1300 Wavre

#### CONTACT PERSON

**Olivier Desenfans**  
CEO

#### CONTACT DETAILS

+32 10 49 53 63  
contact@m3systems.eu

**Specific competences: PNT testbed, including vulnerabilities (jamming/spoofing) impact analysis. Robust PNT solutions based on multisensor hybridization. PNT expertise and services.**

[www.m3systems.be](http://www.m3systems.be)

# Mirmex Motor SA

SECTORS



# MPP

SECTORS



**Mirmex Motor is a Belgian innovator in micromotor technology, specializing in the design and manufacture of miniature DC motors, motor coils, and actuators.**

Mirmex micromotors offer unmatched compactness and performance density, made possible by a patented technology originally developed in a university lab to address frustrations with the lack of customizable coil options. This breakthrough enables optimized coil shapes that were previously impossible to achieve with conventional manufacturing methods. Today, this cutting-edge technology is available at scale for Defence OEMs and is superior to Swiss, German, and American equivalents.

Mirmex micromotors significantly enhance the design flexibility of motorized devices, particularly those that operate on battery power or require a high degree of compactness and dynamic performance. The distinctive characteristics of Mirmex micromotors are especially valued in the following Defence applications:

- Low-inertia, high-torque positioning and aiming systems.
  - Robust, high power-density actuators optimized for limited volume footprints.
  - Custom-engineered, small-size brushless slotless electric micromotors for general-purpose Defence applications.
- The motors from Mirmex are made in Belgium and already used by large Defence consortiums.

#### Specific competences:

**Robotics, mechatronics, actuators, missile control, target acquisition.**



**MPP is a mission-critical partner in non-destructive testing (NDT), delivering high-reliability inspection services for aerospace and defence.**

Combining 8 complementary methods with advanced facilities, MPP operates a multimethod composite laboratory featuring digital radiography, CT scan, and robotized shearography and thermography for large structures, as well as on-site interventions for critical assets.

#### Defence / dual-use positioning

MPP supports defence and dual-use programs where failure is not an option. EN9100 and Nadcap accredited, MPP ensures structural integrity, compliance and operational readiness of critical components across demanding environments.

#### Main applications

Aircraft structures, propulsion systems and high-value components, metallic and composite, including large and complex parts.

#### HEAD OFFICE

Parc Industriel des Hauts-Sarts

1<sup>ère</sup> Avenue 66

4040 Herstal

#### CONTACT PERSON

**Christophe Loffet**

Business Development Manager

#### CONTACT DETAILS

+32 42 48 06 00

[clf@mpp.be](mailto:clf@mpp.be)

# Mustad AG

SECTORS



## HEAD OFFICE

Industrie Strasse 30  
4700 Eupen

## CONTACT PERSON

**Pierre DEFECHEREUX**  
Managing Director

## CONTACT DETAILS

+32 87 63 98 90  
direction@mustad.be

Mustad AG specializes in precision mechanical subcontracting, focusing on bar turning (décolletage) and five-axis milling for world-leading companies in the Defence sector. We are located at the Belgian-German border in the German-speaking region, with a logistical organization covering all of Europe and the United States.

We produce series of components ranging from 1,000 to 1 million pieces such as FLASH HIDDERS, FIRING PINS, BREECH BLOCKS, COVERS, SELECTOR LEVELS, TRIGGERS, FIRING PINS, UPPER & LOWER, SLIDE, FRAMES, etc. for:

- small-caliber weapons like assault rifles or handguns for world leaders
- machine guns
- ammunition components: including .50 caliber ammunition and rounds from 30 to 120 mm.
- Rockets
- Grenades and grenade launchers

Mustad is also capable of reverse engineering and developing components, accessories or sub-assemblies for weapons.

Founded in 1948, our company boasts several decades of expertise in the sector, with a state-of-the-art machine park that ensures our competitiveness.

### Specific competences:

**Components for small-caliber weapons like assault rifles or handguns, machine guns, ammunition components up to 120 mm, Rockets, Grenade and grenade launcher.**

# NanoPyro

SECTORS



## HEAD OFFICE

Mont Saint Roch 45  
1400 Nivelles

## CONTACT PERSON

**Laurent Desmaret**  
CEO

## CONTACT DETAILS

info@nanopyro.be

NanoPyro was created on 22 February 2023 as a spin-off of the Royal Military Academy of Belgium. It develops and produces energetic nanomaterials for the civil, aerospace and defence industries.

The technology developed is the result of more than 30 years of experience in the knowledge and characterization of energetic materials and nanoporous materials. The result is a technological platform for the creation of a new family of energetic materials. NanoPyro exploits the patent exclusively.

The energetic materials resulting from this technology benefit from all the advantages of nanomaterials without the disadvantages of nanoparticles. The physical manufacturing process allows the development of new energetic materials in a very short cycle. In addition, the manufacturing process is waste-free and energy-efficient.

Finally, this technology is able to meet the need for alternatives that comply with the REACH legislation by offering products without heavy metals and/or low toxicity.

### Specific competence:

**Energetic Materials**

SME

# NEMAND

SECTORS



SME

# nSilitation

SECTORS



Founded in 2016 and based in Brussels, NEMAND Consulting Ltd. is a firm specialized in aviation engineering, strategic advisory, and civil-military coordination in air traffic and airspace management. Its location near key European institutions and EUROCONTROL reinforces its position as a trusted international partner.

#### HEAD OFFICE

Rue Juste Lipse 19  
1040 Brussels

#### CONTACT PERSON

**Andrej Nemec**  
Founder & CEO

#### CONTACT DETAILS

+32 498 22 18 17  
info@nemand.be

NEMAND is ISO 9001:2015 certified and an active member of BSDI, AGORIA, and the Skywin Aerospace Cluster. The company supports both public and private stakeholders with deep expertise in ATM, aviation safety, security, and GNSS implementation.

Its clients include EUROCONTROL, the European Commission, EBAA, and NATO. Through resilient and forward-looking solutions, NEMAND contributes to safer, more efficient airspace operations worldwide.

**Specific competences:**  
Airspace Management, Civil-Military Coordination, GNSS Implementation, ATM Strategy & CONOPS Development

[www.nemand.be](http://www.nemand.be)



#### HEAD OFFICE

Rue Louis de Geer 6  
1348 Louvain-la-Neuve

#### CONTACT PERSON

**Thierry Delmot**  
General Manager

#### CONTACT DETAILS

+32 10 39 21 40  
info@nsilitation.com

**Specific competences:**  
ISO-9001

[www.nsilitation.com](http://www.nsilitation.com)

nSilitation owns silicon proven experience in the design and manufacturing of advanced analog and mixed-signal ICs dedicated to harsh environments (automotive, space, industrial, high-temperature, high-voltage, nuclear,...) and demanding applications.

Many ICs or semiconductor IPs of nSilitation are operating today in complex environment with proven lifetime robustness and reliability. Sensors and actuator ICs, signal processing unit ICs, power management controllers ICs, image display,... are all actual examples of chips made by nSilitation running in production today. ISO pulses, DPI, extended DFT/DFY, DFMEA and FuSA are part of the standard design process of nSilitation.

Up to 100V operating range with 200V isolation can be provided.

SME

# Open Engineering

SECTORS



open  
engineering

#### HEAD OFFICE

Avenue de l'Expansion 7  
4432 Alleur

#### CONTACT PERSON

**Pascal De Vincenzo**  
General Manager

#### CONTACT DETAILS

+32 4 367 89 43  
info@open-engineering.com

Open Engineering is an independent European high-tech supplier offering multiphysics simulation engineering services and advanced 3D simulation software solutions.

With a focus on innovation and performance, Open Engineering delivers tailored simulation tools designed to address complex engineering challenges across various industries.

Our OOFELIE::Multiphysics solver is used to generate virtual prototypes. This entails creating detailed and precise simulations of your system that can be used to anticipate outcomes, test multiple scenarios, and refine your ideas without the expense of real-world testing.

Open Engineering has built its reputation by providing high value-added services in the space, aeronautics, defence, automotive and microelectronics sectors for customers such as AMOS, ArianeGroup, ESA, FN Herstal, Fokker Technologies, Forge de Zebrugge, Hamamatsu, Hyundai, John Cockerill, Lambda-X, Luxspace, MECAR, MicroGen, OHB, ONERA, Safran or Thales.

**Specific competences:  
Modelling and Simulation**

[www.open-engineering.com](http://www.open-engineering.com)

SME

# Optrion

SECTORS



#### HEAD OFFICE

Avenue du Pré Aily 25  
4031 Angleur

#### CONTACT PERSON

**SIMON Daniel**  
Chairman

#### CONTACT DETAILS

+32 4 287 10 70  
info@optrion.be

OPTRION, founded in 1999 as a spin-off from CSL, is a dynamic and specialized high-tech SME. We apply our knowledge and experience to provide non-destructive shearography inspection systems. We benefit from our own in-house R&D capabilities for our hardware and software solutions, giving us unrivalled responsiveness and flexibility.

OPTRION markets its DeFinder range of complete shearography inspection systems, or custom-built installations. These systems are used for inspection in research laboratories, in production or in maintenance. They enable fully digital non-destructive testing and can be fully robotized. Our robotized solutions benefit from the latest developments and are particularly comprehensive.

Throughout its history, OPTRION has worked with some of the biggest names in the aeronautics, space and Defence industries, including various entities in the Safran and Thales groups, Ariane, ESA, AIRBUS, etc.

[www.optrion.be](http://www.optrion.be)

# Patria Belgium Engine Center

SECTORS



# Pix Coating

SECTORS



## Patria

**Patria Belgium Engine Center is a Center of Excellence for I- and D-level MRO services and borescope inspection of the F100-PW engine, in all its configurations (-200, -220, -220E, -229).**

Patria supports more than 15 Air Forces including USAF for 40+ years. With its comprehensive in-house NDT, Inspection and component repair capabilities, Patria provides a single and complete MRO solution to every customer requirement.

### Our competitive capabilities:

- World-class provider of I- and D-level MRO services on the F100-PW-200/220/220E/229.
- Comprehensive inspection and non-destructive testing portfolio.
- Extensive in-house parts-repair capabilities.
- Superior spare parts configuration management, forecasting and provisioning.
- Borescope inspection at 200/300Hrs.
- Technical and professional expertise based upon legacy in-house production of the F100-PW engine for major European air forces.

### Qualifications, certifications, and export authorizations

- Extensive Export Licensing Coverage and Support for all end users
- USAF SAR Package approved
- Authorized Economic Operator (AEO)
- ISO 9001
- EN/AS 9110
- BMAR-145
- NLMAR-145

#### HEAD OFFICE

Rue du Fonds des Fourches 23  
4041 Herstal

#### CONTACT PERSON

**Manuel Sidiropoulos**  
Directeur Général

#### CONTACT DETAILS

+32 42 70 70 53  
pbec.info@patriagroup.com



#### HEAD OFFICE

Rue des Trois Entites 16  
4890 Thimister-Clermont

#### CONTACT PERSON

**Nicolas Houben**  
CEO

#### CONTACT DETAILS

+32 87 44 74 41  
n.houben@pixcoating.com

**Pix Coating is a treatment surface and paint applicator specialized in complex coatings. We specialized mainly in Space, Defence and aeronautics industries.**

We work on every substrate, from steel to aluminium, passing by copper, lead, titanium or even composite materials. We are able to fit your specifications as well as accompanying you to specify your needs.

We can work on prototypes as well as mid to great series (from 1 single part to thousands of parts). We can realise every control you desire and produce controls lists and certificate of conformance.

We are qualified by most of the belgian Defence producers and are able to develop a qualification program if needed.

We can also finish surfaces with surfacers on composites prior to paint, this particular capability allows us to repair defectuous parts as well.

# Plastisart

SECTORS



# PTS Machining srl

SECTORS



Plastisart is a company specialized in the manufacturing of all types of plastic parts, components, and equipment, and operates across a wide range of sectors.

Plastisart meets all your plastic material needs from the simplest single part to assembled multi-material systems, all the way to equipment integrating mechanical or electrical functions. From prototypes to small and medium production runs.

To ensure optimal results, Plastisart relies on its expertise in working with a wide range of thermoplastics, from basic mechanical-grade materials to multifunctional and smart composites.

Renowned for many years for its advanced expertise in thermoforming and other plastic processing technologies, Plastisart brings you over 50 years of experience in the design and production of plastic parts and components.

Its advanced technical skills and ongoing knowledge of evolving plastic materials allow the company to offer you the most suitable solution, perfectly tailored to each situation and budget for a wide variety of industries, throughout Europe.

Right from the start of your request, Plastisart provides full project support, managing your project from A to Z. This comprehensive management approach is built on strong partnerships and regular communication. As an industrial client, you benefit from a process optimization strategy integrated throughout the entire project.

#### HEAD OFFICE

Rue du Berlaimont 17  
6220 Fleurus

#### CONTACT PERSON

**Deltenre Jean François**  
CEO

#### CONTACT DETAILS

+32 71 82 44 20  
info@plastisart.com



#### HEAD OFFICE

Rue de la Fagne, 1A  
4920 Harzé

#### CONTACT PERSON

**Yves Bareel**  
CEO

#### CONTACT DETAILS

+32 4 360 73 03  
yves.bareel@ptsmachining.be

PTS Machining is a subcontractor active in the production of precise machined parts of medium and large sizes for the Defence, Space and Aeronautics sectors.

PTS manufactures control jigs and fixtures, cutting and stamping tools. PTS manufactures custom hydraulic presses as well as precise machined welded assemblies.

PTS is a end-to-end provider with project execution from A to Z including :

- Design
- Manufacturing (welding + machining)
- Heat treatments
- Surface treatments
- QA & Control on CMM and Laser Scan
- Project Management & Planning

Welding and machining of the following materials: steel, stainless steel, aluminum, titanium, brass, copper

PTS is certified ISO 9001 :2015

SME

# Q-SQUARE Aerospace

SECTORS



LC

# SABCA

SECTORS



Bring expertise in risk assessment methodologies (RAMS) and integrated logistic support (ILS) considerations in the design, manufacturing and maintenance of Defence products.

#### HEAD OFFICE

Rue de Rodeuhaie 1  
1348 Louvain-la-Neuve

#### CONTACT PERSON

**Frédéric Wilquem**  
Founder & Associate Director

#### CONTACT DETAILS

+32 485 44 25 78  
info@qsquare.aero



#### HEAD OFFICE

Chaussée de Haecht 1470  
1130 Bruxelles

#### CONTACT PERSON

**Alexia Grabowski**  
Communication Manager

#### CONTACT DETAILS

+32 2 729 55 11  
Alexia.Grabowski@sabca.be

Through its 100 years' experience in design & manufacturing (incl. Engineering, integration, testing & certification), SABCA offers a full range of ready-to-fly solutions and components to its civil, military aviation and space customers, with industrial footprint in the 3 regions (Brussels, Wallonia and Flanders) and in Morocco.

With its sister companies, SABCA Technologies and SABCA Limburg, SABCA Group is a recognized leader in the design, construction, and assembly of integrated metallic and composite aerostructures as well as the development, manufacturing, and supporting of actuators for advanced thrust vector control for space launchers and flight control systems for military and civil aviation

SABCA Defence activities include producing (composite) parts for the F-16, the A400M, the MQ-9B drone and the F-35 fighter.

SABCA Group counts 1000+ employees for a turnover of 160+ m€.

# Sabena Engineering

SECTORS



# Safran Aero Boosters

SECTORS



**Sabena Engineering (SNE) is an international MRO&U independent provider offering sustainable maintenance, repair, overhaul & upgrade solutions to commercial and military aviation.**

Its Defence activities cover a full spectrum of maintenance, upgrades, engineering support and mission ready services across a wide range of platforms (eg F16, A400M, F 35, MQ9B, PC7, E-3 AWACS or Textron SkyCourier) and locations (through its specialized go-teams).

SNE is the main MRO&U partner of the Belgian Defence for more than 50 years and a strategic MRO&U partner to NATO and its Allied Air Forces.

SNE has developed strong partnerships with key Defence OEMs (incl. Lockheed Martin, General Atomics, Airbus Defence) and is one of 3 Global Depot Level Centers with unique repair capabilities.

SNE counts over 900 employees for a turnover of 155m€ with industrial assets in Belgium and Morocco and operates on 16 international airports and military bases. For more information: [www.sabena-engineering.com](http://www.sabena-engineering.com)

#### HEAD OFFICE

Avenue Emmanuel Mounier 2  
1200 Bruxelles

#### CONTACT PERSON

**Alexia Grabowski**  
Communication Manager

#### CONTACT DETAILS

[communication@sabena-engineering.com](mailto:communication@sabena-engineering.com)



**Safran Aero Boosters designs, develops and manufactures Low Pressure Compressors, Oil Equipment and Engine Test Benches (military and civil market).**

The company equips most of the in-service civil aircraft as well as the European Ariane launchers.

Our strengths for Defence market : 70 Years experience in military engines, 50 Years of support to Air Forces Worldwide, 600 F100 engines manufactured (Including test and check-out), 4 Operating Test Cells in Belgium, 60 years of expertise in the field of test cell engineering.

Our military references : 8 Major military programs F100-P&W, F110-GE, TP400-EPI, Tyne-RR, Derwent-RR, Avon-RR, J79-GE, ATAR 9C-SAE / Final Assembly & Check Out (FACO) legacy.

#### HEAD OFFICE

Route de Liers 121  
4041 Herstal

#### CONTACT PERSON

Jean-François Cortequisse  
Head of Institutional Relations

#### CONTACT DETAILS

+32 475 694 723  
[jean-francois.cortequisse@safrangroup.com](mailto:jean-francois.cortequisse@safrangroup.com)

**Specific competences:  
Jet engine test benches.**

SME

# Sagita

SECTORS



SME

# SCouP-ChP Consult

SECTORS



**Drones: We develop VTOL drones at intended use: surveillance of extended areas, naval or terrestrial.**

Engineering: Aerodynamic and structural design of centrifugal compressors and of contrarotating radial turbines.

Design of coaxial helicopter rotors and control system.

#### HEAD OFFICE

rue de la cloche, 7  
4130 Esneux

#### CONTACT PERSON

**Hubert ANTOINE**  
Director

#### CONTACT DETAILS

+32 4 97 52 89 64  
h.antoine@sagita.be



#### HEAD OFFICE

Clos de Priesville  
4845 Jalhay

#### CONTACT PERSON

**Christophe Promper**  
Administrator

#### CONTACT DETAILS

+32 471 78 38 40  
cpromper@scoup.eu

Based on its deep knowledge about Shape Memory Alloys (SMA), Aerospace and weapon systems, SCouP activity focuses on components including customised SMA couplings for tubes (for first mount and repairs and maintenance, e.g. for satellite or air-craft hydraulics), SMA reinforced textiles (for personnel armour and ammo pouches), morphing composites (for variable geometry radiators and air-foils) super-elastic joints (e.g. as an alternative to hinges) and various actuator concepts. In addition, SCouP works on SMA based anti-cook-off features for small and large caliber ammunition.

SCouP is a young company that was founded in 2020 on the heritage of a succession of European Space Agency projects related to SMA tube couplings and various military and civil SMA applications.

Currently, the main customers are major European space companies.

**Specific competence:  
Fluid Systems optimisation**

SME

# SENSY

SECTORS



SME

# Serviplast

SECTORS



Established in 1985, SENSY is a Belgium-based designer and manufacturer of high-precision standard and custom-made load cells, load pins, and force and torque transducers. Our solutions are deployed in more than 90 countries worldwide, supporting mission-critical applications across highly demanding industries.

#### HEAD OFFICE

Zoning industriel de Jumet  
Allée centrale  
6040 Jumet

#### CONTACT PERSON

**Serge Sendrowicz**  
CEO

#### CONTACT DETAILS

+32 71 25 82 00  
srs@sensy.com

Engineered for reliability and accuracy in extreme environments, SENSY sensors and load cells provide advanced capabilities for load monitoring, force and torque measurement, overload protection, and level control. They are fully tailored to integrate seamlessly into complex and safety-critical systems.

SENSY is EN 9100 certified, a key aerospace and Defence quality standard, positioning the company among the very few manufacturers worldwide in the field of force measurement sensors and load cells to hold this certification.

This recognition reflects our commitment to the highest levels of quality, traceability, and operational excellence required by Defence and aerospace programs.

With a strong presence in Defence, aerospace, and Oil & Gas, SENSY delivers robust, high-performance sensing solutions where precision and reliability are not optional, but essential



#### HEAD OFFICE

Rue du Marché Couvert 42  
6600 Bastogne

#### CONTACT PERSON

**Benoît Cougnon**  
Manager of Industry Pool

#### CONTACT DETAILS

+32 61 240 670  
benoit.cougnon@serviplast.be

For over 40 years, Serviplast has provided in-depth expertise in the development and injection molding of your plastic parts.

We are committed to quality and deadlines with a goal of “zero defects – zero delays,” all while maintaining a competitive pricing policy. Our clients come from highly demanding sectors such as aerospace, Defence, automotive, rail transport, electrical and electronic equipment, home and industrial applications.

Serviplast holds ISO 9001 and ISO 14001 certifications, attesting respectively to their quality standards and environmental commitment. Serviplast also carries a social mission, the integration of disabled people in the workforce.

#### Products and Services

Serviplast supports you throughout your project to optimize the production of your plastic component. Eco-design integration is at the heart of our expertise through material selection, process optimization, carbon footprint analysis, and life cycle assessment to develop your product with a sustainable approach.

To provide a complete service, Serviplast supports you from product industrialization to shipping through its various areas of expertise: 3D printing for prototyping, tool manufacturing, injection molding with or without overmolding, technical assembly, connectivity and packing.

We operate a constantly updated machine park with 26 injection presses ranging from 6 to 300 tons.

# Shur-lok International

SECTORS



Shur-Lok is a world leader in the design and manufacture of critical performance Fasteners which have become industry standards for Aerospace civil and military applications.

Shur-lok has been a pioneer in Aerospace Specialty Fasteners for 50 years with also a strong expertise in producing hard metal machined parts for Aircraft engine & airframe, Helicopter or Satellite components. Shur-Lok is EN9100 & NADCAP certified and processes all aerospace materials.

SL Fasteners are used in high vibration and load transfer applications to provide superior alignment, resistance to wear and movement, as well as ease of assembly. Key product lines include bearing locknuts, barrel nuts, expandable diameter fasteners, studs and inserts, lockwireless fittings, and honeycomb sandwich panel inserts.

Shur-Lok serves worldwide customers from two design and manufacturing centers: 75,000 sq. ft. facility in California and 48,000 sq. ft. facility in Belgium.

#### Specific competences:

Specialty fasteners & high precision machined parts.

# Sobelcomp

SECTORS



Sobelcomp provides integrated composite solutions to our customers' issues to meet their needs in terms of supplying parts in composite materials.

Solution oriented, we provide answers to several issues with:

- Weight reduction
- Function integration
- Environmental resistance
- Functional design

As a company active in the aerospace, Defence and automotive sectors, it is committed to a strong quality approach and has had its quality management system certified according to the AS / EN / JISQ 9100 and ISO 9001. Also convinced that innovation is the driving force of its activity, Sobelcomp has invested for many years in the development of its design office.

The services we offer through our design office are:

- Study and design of parts, molds and production tools
- Finite element calculation
- Qualification of processes and materials

Thanks to our workshop and our trained operators, the parts are:

- Manufactured using different processes like RTM, RTM Light, Infusion, Pre preg
- Assembled by gluing, riveting, etc.
- Painted in our paint booth
- Controlled and measured

#### HEAD OFFICE

Rue de l'Economie 13  
4431 Loncin

#### CONTACT PERSON

**Thaels John**  
Gérant

#### CONTACT DETAILS

+32 4 264 41 21  
[thaels.john@sobelcomp.be](mailto:thaels.john@sobelcomp.be)



Sonaca is a major tier one in aerospace and Defence market with recognized experience. With 6700 employees spread over 27 plants around the world, we serve a widespread portfolio of civil, Defence and space customers.

Sonaca's key strengths lie in its proven and recognized capabilities across the entire development cycle through to cost-efficient serial production. This expertise extends across the full life cycle, including MRO activities, for aircraft (both manned and unmanned), as well as for satellites and space launcher components and systems.

Sonaca's heritage is deeply rooted in the Defence sector, where the company has built a strong and longstanding expertise. Leveraging its global footprint, Sonaca collaborates closely with leading OEMs and Tier 1 and Tier 2 partners across a wide range of platforms, including fighter aircraft, trainers, helicopters, transport aircraft and UAVs. The company also supports major legacy Defence programs through structural work, maintenance and repair activities, notably on platforms such as the Airbus A400M and A330 MRTT, Airbus C295, Lockheed/Sikorsky H-60 helicopter, Boeing F-15, F/A-18, P-8 and KC-46, as well as the Lockheed F-16 and F-35 and the Embraer KC-390.

Sonaca also delivers robust aftermarket solutions, closely aligned with customer needs, providing 24/7 worldwide support on an AOG basis, including spare parts, repair services and engineering solutions.

Building on its unique combination of Defence expertise and large-scale civil production capabilities, Sonaca stands out as a reliable partner for OEMs seeking to meet the growing production and operational demands of the Defence industry, particularly in today's challenging environment.

#### HEAD OFFICE

Route Nationale 5  
6041 Gosselies

#### CONTACT PERSON

**Nicolas Van Hille**  
Research and Technology Manager

#### CONTACT DETAILS

Nicolas.VANHILLE@sonaca.com  
+ 32 71 25 51 11



#### HEAD OFFICE

Rue Vaçale 5  
4140 Sprimont

#### CONTACT PERSON

**Jean-Philippe THOMAS**  
CEO/Managing Director

#### CONTACT DETAILS

+32 4 384 01 10  
info@soudobeam.be

**Specific competence:  
Welding**

Soudobeam is a Belgian manufacturer of mechanical sub-assemblies for all industrial sectors. In particular, we offer the precision machining of components and their assembly by Electron-Beam Welding. This high-density of energy process, held under vacuum, delivers superior metallurgical quality and mechanical strength to conventional processes. We manage your project from design to large series.

Electron-Beam Welding is particularly suitable for metal assemblies subject to high stresses (thermal, dynamic, chemical, mechanical) or made from materials that are notoriously difficult to weld (aluminum, copper, nickel, titanium, hardenable steel, specific stainless steel, etc.). It also offers considerable design freedom. As a mechanical sub-equipment supplier, we provide manufacturing controls as well as complementary services such as heat treatment and surface treatment.

All our achievements are framed by our ISO9001-compliant quality system.

Our welding services are defined and supervised by International Welding Engineer (IWE).

SME

# SPACEBEL

SECTORS



LC

# Starion

SECTORS



**SPACEBEL contributes to a safe and sustainable planet and inspiring space exploration by engineering solutions for the global space ecosystem.**

SPACEBEL, Belgian based company with offices in France and Poland (N7 Space), is a long-established European leader in space systems and software engineering, serving space agencies, major aerospace companies, civilian and defence related governmental bodies, EU institutions and industry stakeholders.

SPACEBEL designs, develops and validates innovative software solutions for civilian and defence space ecosystem purposes:

- AI & EARTH OBSERVATION APPLICATIONS
- DATA MANAGEMENT
- GROUND SEGMENT
- ON-BOARD SOFTWARE
- MODELLING AND SIMULATION
- SUPPORT FOR SPACEPORTS AND LAUNCHERS
- 

The company owns 500m<sup>2</sup> clean rooms ranging from ISO class 5 to ISO class 7.

So far, SPACEBEL has contributed to more than 50 successful space missions, including flagship Space4Defence and dual-use missions such as Helios-2, Pléiades, CSO, CERES, Odin's Eye, Yoda, Hera, RAMSES, ...



**Starion is a European company providing engineering and cybersecurity services and solutions to the space and defence sectors, as well as to critical infrastructure operators across Belgium and Europe.**

For over three decades, Starion has been investing in the development and operation of tailored systems and solutions for its clients. We offer a range of advanced solutions tailored to the needs of modern military operations, spanning Earth observation, resilient PNT, electromagnetic spectrum monitoring, cybersecurity – in particular for space systems and UAVs – AI-driven military technologies, and quantum key distribution for secure communications.

Starion is a pioneer in concurrent design, leveraging this collaborative engineering methodology for over 20 years to optimise processes, improve efficiency and accuracy, and reduce costs of complex engineering projects.

Our purpose-built software and specialised services have proven especially valuable in supporting defence entities in the specification and design of complex military systems. The company is ISO 9001 and ISO 27001 certified.

#### HEAD OFFICE

Rue des Chasseurs Ardennais 6  
LIEGE science park  
4031 Angleur

#### CONTACT PERSON

**Jean-Christophe ARMSLAG**  
Business Development Manager  
Defence & Security

#### CONTACT DETAILS

+32 4 361 81 11  
defence@spacebel.com

#### HEAD OFFICE

Rue des Etoiles 140  
6890 Libin

#### CONTACT PERSON

**Cédric Seynat**  
VP Commercial Strategy & Execution

#### CONTACT DETAILS

+32 10 48 72 70  
info@stariongroup.eu

SME

# Technical Airborne Components (TAC)

SECTORS



TAC designs, develops and manufactures rods, connected mechanical parts and components for aeronautical applications.

TAC had been a major supplier to the aerospace industry for the last 41 years.

TAC has an extended experience of the rod design and manufacturing. We can address a wide range of application like wing and flight control, structure, doors, hold open rods or special application in various materials as aluminium, CRESS, titanium, Inconel or composites. We are a dependable supplier and can testify of proven records with major air framers and sub-tiers.

TAC produces Standard rods, adjustable rods, hold open rods (telescopic or foldable), critical monobloc rods, various rod ends : clevis, ball bearings, with bushes Air framers : Airbus A320, A330, A350, A380, ATR 42/72, Leonardo helicopters, Airbus Helicopters, Bombardier, Dassault, Pilatus, Embraer. Sub-Tiers : Latécoère, Daher, PFW, Stelia, GKN, Fokker, Lisi, etc.

#### HEAD OFFICE

Rue des Alouettes 141  
4041 Milmort

#### CONTACT PERSON

**Pol Delcour**  
Sales Director

#### CONTACT DETAILS

+32 42 89 97 50  
sales@tac.be

[www.tecairco.be](http://www.tecairco.be)

LC

# Telespazio Belgium

SECTORS



Telespazio Belgium, a subsidiary of Telespazio (a joint venture between Leonardo, 67%, and Thales, 33%), provides cutting-edge services and applications, engineering services and support in the field of space programs and high technology projects.

As part of one of the world's leading operators in the field of satellite solutions and services, Telespazio Belgium is at the forefront of providing advanced and innovative satellite services in navigation, earth observation and space operations.

Present since 1982 in Belgium, Telespazio Belgium has more than 40 years of experience and uninterrupted collaboration with space agencies and Satellite Operators.

Telespazio Belgium's specific areas of activity span from Satellite Technology to Telecommunications, from Information Technology to Users' Application Development & Services. Telespazio Belgium endeavours to provide for high-level performance systems which encompass design, hardware & software development, integration and operation.

#### HEAD OFFICE

Rue de La Roche, 38G  
6600 Bastogne

#### CONTACT PERSON

**Iacopo Vannucci**  
Innovative Solutions  
Business Developer

#### CONTACT DETAILS

+32 61 230 004  
iacopo.vannucci@telespazio.com

[www.vitrocisetbelgium.com](http://www.vitrocisetbelgium.com)

# Thales Belgium

SECTORS



# V2i

SECTORS



#### HEAD OFFICE

Rue en Bois 63  
B-4040 Herstal

#### CONTACT PERSON

**Lou Uniack**  
Strategy, Marketing  
& Communication Director

#### CONTACT DETAILS

+32 492 72 20 03  
koumba-k.dianka  
@external.thalesgroup.com

**Thales Belgium, is a 100% subsidiary of the French company Thales Group.**

Thales's presence in Belgium is rooted in a long history of industrial footprint that dates back to the 1970s. Over the years, Thales Belgium has developed its industrial and technological capacity across the country and has a wide portfolio with solutions covering all major areas of the group, including Defence & Security, Aeronautics & Space, and Digital Identity & Security.

Thales in Belgium aims to grow and innovate to be constantly at the cutting-edge of technologies. That's why Thales Belgium has strong relations with the best Belgian Universities and research centers to contribute in the innovative ecosystem of Belgium and to recruit the best talent to support its R&D. Also, Thales Belgium has developed close ties with the Belgian Industry over many years and is present in the main Belgian industrial groups and conglomerates.

Thales Belgium employs over 1,300 people on 14 sites in Belgium to develop products and solutions that contribute to a safer, greener and more inclusive world.



#### HEAD OFFICE

Avenue du Pré Aily 25  
4031 Angleur

#### CONTACT PERSON

**SIMON Daniel**  
Chairman

#### CONTACT DETAILS

+32 4 287 10 70  
info@v2i.be

**With more than 20 years of experience, V2i is a high-tech R&D company specialized in vibration engineering for critical Defence systems. V2i combines advanced simulation, experimental testing, and structural analysis to improve the safety, reliability, and performance of mission-critical equipment.**

We support Defence programs from design to validation by identifying structural weaknesses early, optimizing dynamic performance, and ensuring compliance with military standards.

Our expertise covers four main areas: dynamic simulation, vibration testing, modal analysis, and quality monitoring solutions. We develop numerical models to predict system behavior under operational and extreme environments, including finite element modeling, vibration and shock analysis, and simulation-test correlation.

Our ISO 17025 accredited laboratory performs sine, random, and shock tests for environmental qualification and system validation. V2i also develops tailored instrumentation and data processing systems for manufacturing quality and structural health monitoring.

SME

# X-RIS

SECTORS



## Values & Mission

X-RIS's number one priority is to develop portable and stationary digital radiology solutions that are very user-friendly and intuitive for industrial, laboratory and security applications without skimping at any time on the image quality.

## Story

X-RIS was founded in 2010 and since then has developed its own range of X-ray generators, detectors and its software platform: Maestro. X-RIS also designs and manufactures its own mechanical and electro-mechanical solutions for Dxbox cabinets and special solutions.

## Team

The company counts today 23 collaborators and is particularly technologically oriented: more than two-thirds of the team are graduated engineers. We also collaborate with several universities and R&D centres in Belgium and abroad. X-RIS can rely on a young, dynamic and skilled team surrounded by experienced staff, all dedicated both to the development of our products and to provide full support to its partners.

## HEAD OFFICE

Rue d'Abhooz 25  
4040 Herstal

## CONTACT PERSON

Poelast Nicolas  
CEO

## CONTACT DETAILS

+32 43 67 07 92  
info@xris.eu/

Specific competence:  
NDT.

[www.xris.eu](http://www.xris.eu)



# Walloon Defence Actors

Research Centers  
& Universities





Cenaero is a private non-profit applied research center dedicated to pioneering industrial research and development, particularly in the field of numerical modeling and simulation technologies.

Drawing on its simulation skills recognized in the aeronautics sector, Cenaero develops tailor-made solutions not available on the market and supports companies in niches. Cenaero combines numerical simulation and artificial intelligence with high-performance computing for challenges in the fields of advanced materials and manufacturing, multi-physics flows, and multidisciplinary optimization.

Cenaero provides distinctive expertise and engineering services for high performance composites, metallic manufacturing processes, multi-scale mechanics through lifetime, high resolution turbulent flows, hypersonic flows and phase-changing materials, thermo-fluid processes, design for manufacturing, and turbomachinery design.

Cenaero operates the Tier-1 Walloon supercomputing infrastructure ([tier1.cenaero.be](http://tier1.cenaero.be)) for fundamental, applied and industrial research.

#### HEAD OFFICE

Rue des Frères Wright 29  
6041 Gosselies

#### CONTACT PERSON

**Philippe Geuzaine**  
General Manager

#### CONTACT DETAILS

[info@cenaero.be](mailto:info@cenaero.be)

#### Specific competences:

**Multiphysics Flows, Advanced Materials & Manufacturing, Multidisciplinary & Multilevel Optimization**



#### HEAD OFFICE

rue du Travail 5  
4460 Grâce-Hollogne

#### CONTACT PERSON

**Olivier Jolois**  
R&D Manager

#### CONTACT DETAILS

[oj@centexbel.be](mailto:oj@centexbel.be)

Centexbel is the Scientific and Technical Centre of the Belgian Textile Industry, recognized for its central role in textile and polymer innovation in Belgium and across Europe. Its activities include applied research, testing and certification according to international standards.

The centre has expertise in the development of technical textiles with high resistance to cutting, abrasion, fire, and puncture - properties that are essential for protective equipment. It also designs lightweight textile and composite structures based on high performance fibers, improving shock absorption, mechanical strength, and protection.

Centexbel's expertise also extends to smart textiles, a strategic sector integrating sensors, conductive fibers, and flexible circuits. These innovations enable garments capable of measuring physiological parameters, tracking position, or transmitting data, with applications in healthcare, sports, industry, and demanding operational environments.

Finally, Centexbel is strongly committed to the transition toward sustainable materials, working on the recycling of technical textiles.



As an applied research centre in the field of ICT, CETIC's mission is to support economic development by transferring the results of the most innovative research in ICT to companies, particularly SMEs.

Thus, CETIC helps companies with the integration of technological breakthroughs in their products, processes and services, enabling them to innovate faster, save time and money and develop new markets. CETIC develops its expertise in key technical areas related to Big Data, Cloud Computing, the Internet of Things, Combinatorial Optimisation, Software Quality through model-based approaches.

These fields of expertise are combined into innovative solutions in AI, Cybersecurity and autonomous systems in application domains of primary importance to society, such as health, smart mobility, energy and industry as well as in Defence and security sector.

All expertise areas are continuously improved through CETIC's active involvement in European and regional projects.

#### HEAD OFFICE

Avenue Jean Mermoz 28  
6041 Charleroi

#### CONTACT PERSON

**Jean-Christophe Deprez**  
Director of Research  
& Innovation

#### CONTACT DETAILS

+32 71 159 362  
info@cetic.be



CRM Group is a collective research centre having as Core Members two major worldwide steel companies and as Associated Members numerous companies producing non-ferrous metals, providing services to the steel industry or promoting the use of metals.

We have been entrusted with the mission of creating value for our Members through innovation in metallic products, metallic solutions and associated production processes.

Our technical and R&D services are also available to external companies, with a special focus on services to SMEs and towards European, Belgian and regional economies.

Based on our competencies and facilities, we are developing solutions for different sectors among which Defence and we are involved in different projects with Walloon industrials of the Defence sector (ex Herstal group, John Cokerill Defence, Thales).

Examples of CRM's competencies, technologies and solutions for military applications:

- Laser cladding, thermal & cold spray technologies for additive manufacturing, functionalization and repair;
- Wet, dry and electrochemical finishing and coatings: selective surface treatments for roughness decreasing, protective coating (wear, corrosion, thermal resistance), hard chromium substitution for arming
- New metallic alloys development
- Printed electronics on 3D parts: sensors, tag and track solutions
- PCM heat storage device
- Stealth solutions by changing IR signature
- Materials characterization and testing
- Hydrogen solutions for energy independence

#### Specific competences:

**Advanced manufacturing and coatings, printed and structural electronics, industry 4.0, stealth solutions.**

# CSL

## Centre Spatial de Liège

SECTORS



# Ecole Royale Militaire

## Royal Military Academy

SECTORS



CENTRE SPATIAL DE LIÈGE

## HEAD OFFICE

Avenue du Pré-Aily  
4031 Angleur

## CONTACT PERSON

**Karl Fleury-Frenette**  
Technology Partnerships  
Program Manager

## CONTACT DETAILS

+32 4 382 46 30  
kfleury@uliege.be

The Centre Spatial de Liège (CSL) has been a cornerstone of space activity development in Belgium since the mid 1960s. CSL offers a wide range of advanced infrastructure for space environmental testing, including five thermal vacuum chambers, two shakers, and a broad suite of specialized equipment, all housed within clean rooms covering more than 1,000 m<sup>2</sup>.

CSL specializes in the development of space optical instruments and has contributed to numerous payloads for space and Earth observation missions.

It also plays a key role in the advancement of enabling space technologies and provides expert services across several domains (optics, space environmental testing, optical coatings thermo-mechanical engineering, and electronics). CSL's capabilities and developments are relevant to the Defence sector, particularly in areas such as : embedded electronic systems, SAR signal processing, laser-based positioning and communication systems, calibration of Earth observation instruments, environmental testing of optical sensors, and end-to-end development of space weather instruments as well as on-board calibration systems for remote sensing payloads. CSL has also contributed to the S-POD, ELECTROHOB, M4, and D-DAMS.



## HEAD OFFICE

Avenue de la Renaissance 30  
1000 Bruxelles

## CONTACT PERSON

**LtCol Pierre Moinet**  
Head of Scientific Research Office

## CONTACT DETAILS

erm-deao-staff-projects-projext  
@mil.be

### Environmental Mechanics and Mobility Applications (EMMA)

The EMMA research pole focuses on the relation between mechanical devices and their environment (vibrations, acoustics, ageing, air quality, sensing) as well as on the performance, stability and technology of mobility platforms in the air, sea, and land domains whether manned or unmanned.

### Signal, Systems & Sensors, Information & Intelligence, Communication (SIC)

The SIC develops a high-level expertise in C4I systems. The research focuses on the processing of data recorded from a wide area of sensors (radar signals and images, optical and thermal images, navigation signals, radio signals, ...) in order to support a decision process in a contested environment.

### Weapon Systems and Ballistics

The activities of the department resolve around the evaluation of survivability of combat systems, internal, external, and terminal ballistics. The experimental work is conducted in the accredited laboratory hosting a 100 m indoor shooting range.

**Specific competence:**  
**Aerodynamics**

[www.rma.ac.be](http://www.rma.ac.be)

<https://www.csl.uliege.be>

# JRI4Space

SECTORS



## HEAD OFFICE

Av. du Pré Aily  
4031 Angleur

## CONTACT PERSON

**Bilal Outirba**  
Liaison Officer

## CONTACT DETAILS

+32 2 650 49 89  
bilal.outirba@ulb.be

**Specific competences:**  
Cybersecurity, Digital twins

[www.space4relaunch.be/jri4space](http://www.space4relaunch.be/jri4space)

JRI4Space is a consortium uniting universities of the Wallonia-Brussels Federation, accredited research centers, Skywin and companies operating in the space sector.

Its objective is to maximize the adequation between academic R&D capabilities with industrial needs. It promotes collaborative research initiatives, such as the Space4Re-Launch project, aimed at developing disruptive technologies.

Key focus areas include on-board instruments, satellite platform and systems, communication technologies and data processing for decision-making tools. The work also contributes to enabling autonomous access to space by addressing the impact of atmospheric re-entry through the development of digital twins, and reusable actuation systems and cryogenic valves for reusable space launchers.

JRI4Space aims to expand into the domains of defence and security, with a focus on dual-use technologies, space debris detection and mitigation, in-orbit servicing, and Lunar and Martian exploration.

# Multitel

SECTORS



## HEAD OFFICE

Rue Pierre et Marie Curie 2  
Parc Initialis  
7000 Mons

## CONTACT PERSON

**Alexandre Vandermeersch**  
Directeur Général

## CONTACT DETAILS

+32 65 34 27 32  
direction@multitel.be

[www.multitel.be](http://www.multitel.be)

Multitel is a Walloon research center that develops technological innovations covering advanced, trustworthy AI models, secure and robust telecommunications and embedded electronics, advanced laser sources, next-generation cybersecurity (quantum / post-quantum).

Together with regional, national and international partners it brings trustable technological solutions that are fundamental to succeed in Defence and dual-use domains.

Our expertise :

### Applied photonics

- high-power fiber lasers
- fiber sensors
- quantum cryptography
- laser spectroscopy

### IoT & Embedded systems

- electronics design & integration
- antenna design
- tailored communication
- EMC / ETSI tests (anechoic chamber)
- over-the-air secure communication testing, electromagnetic signature characterization (anechoic chamber)

### Networks & Cybersecurity

- networks & telecoms
- traditional cybersecurity
- quantum & post quantum security
- new European regulation

### Artificial Intelligence

- AI assisted mission planning (XRL)
- multiview situation awareness
- robust & trusted AI



Sirris is the collective innovation centre of the Belgian technology industry. As a neutral, industry-driven organisation, we support companies in Defence & Security with technological expertise, testing infrastructure and innovation programs.

#### What we do

We support companies across the full innovation journey, from concept to industrialisation:

- Concept generation, validation and project setup
- Advanced product & service development
- Testing & validation in extreme conditions
- Scalable, digital and cyber-secure manufacturing

#### Key capabilities

Our expertise covers a broad range of defence-relevant technologies, including:

- Additive manufacturing for lightweight, repair and distributed production
- Micro-manufacturing and smart miniaturised components
- Climatic and environmental testing for extreme conditions
- Laser texturing and ultra-black, high-emissivity surfaces (e.g. MetaBlack)
- AI-driven and secure image processing systems

#### Specific competence:

Product solutions, advanced manufacturing, digital transformation, innovation management



SynHERA is the only office which represents applied research within the French-speaking Universities of Applied Sciences (UAS), 19, and associated Research Centres, 10, from Belgium.

To support you with your project, SynHERA draws on the scientific skills and expertise of its network. Different skill sets are available from all the categories of the Universities of Applied Sciences (agronomy, technical subject fields, economics, social, educational, paramedic studies and applied arts).

Based on your needs, SynHERA helps you finding the right research partner in our network to collaborate on your R&D projects.

#### HEAD OFFICE

Rue Pieds d'Alouette 39  
5100 Naninne

#### CONTACT PERSON

**Michele Buscemi**  
Knowledge Transfer Officer

#### CONTACT DETAILS

+32 81 41 38 12  
[buscemi.m@synhera.be](mailto:buscemi.m@synhera.be)

#### Specific competences:

Technological engineering, economics, education.



## UCLouvain

### HEAD OFFICE

Place de l'Université 1  
1348 Louvain-la-Neuve

### CONTACT PERSON

**Olivier Tirions**  
LouvainTransfer, Funding Advisor

### CONTACT DETAILS

+32 10 47 25 47  
LouvainTransfer@uclouvain.be

**UCLouvain aims to contribute to the protection of democratic values and institutions, to strengthen the resilience of democratic societies, and to develop innovations that meet high ethical standards, including in the Defence sector.**

With more than 3600 researchers and an annual research budget of 315 M€, research is a true driving force behind UCLouvain's activities. 100+ research groups are active in Defence-related scientific and technological areas such as Advanced Materials, Sensor & Communication, Cybersecurity, Space, Advanced Military Health or Security & Defence Policy.

UCLouvain supports the participation of its researchers in projects with a military purpose, provided that they adhere to its ethical framework and respect its institutional values.

Its knowledge transfer office can advise you to identify the most relevant experts, either to develop a (tailor-made) collaboration, to benefit from expert's advices or to access cutting-edge skills, technologies and infrastructures.



### HEAD OFFICE

50 Avenue F.D. Roosevelt  
1050 Bruxelles

### CONTACT PERSON

**Kevin Deplus**  
Scientific advisor at KTO  
(Knowledge Transfer Office)

### CONTACT DETAILS

+32 473 33 60 16  
kevin.deplus@ulb.be

**The Université libre de Bruxelles (ULB) is actively involved in numerous Defence-related projects, in collaboration with both major industrial players and emerging actors.**

All disciplines in science and engineering are represented. Examples of research topics addressed in industrial collaborations include, among others, fluid mechanics simulation at supersonic speeds, mission control for UAVs and hybrid air-sea drones, drone detection and localization technologies (C-UAV), underwater swarm telecommunications, infrastructure-free embedded positioning and synchronization systems, optimization and computational modelling of materials, model-based real-time system monitoring, artificial intelligence, and the improvement of explosive powder manufacturing processes.

ULB contributes actively to technological innovation and takes part in numerous regional, federal, and European research programs in the Defence sector.



With over 3,100 researchers and 26,000 students, the University of Liège (ULiège) offers deep expertise across science and technology, life sciences, and the humanities. Guided by its core missions—education, research, and civic engagement—ULiège drives scientific excellence and societal impact through interdisciplinary innovation.

A recognized leader in technology transfer, ULiège holds 1,493 patents, 598 licenses, and supports 112 active spin-offs. It partners with industry, government, and international institutions to translate research into impact.

Over 60 ULiège laboratories contribute to Defence and security, supporting Europe's strategic autonomy and operational readiness. These labs provide access to advanced expertise, state-of-the-art infrastructure, joint R&D opportunities, and secure technology transfer. Collectively, they span all Research and Technology focus areas identified by Belgian Defence.

## HEAD OFFICE

Place du 20 Août 7  
4000 Liège

## CONTACT PERSON

**François Kerger**  
Technology Transfer Office

## CONTACT DETAILS

+32 434 98 510  
rise@uliege.be



Research at UMONS is carried out by 1800 researchers in some 100 departments within 10 research institutes.

Each institute brings together the skills of experienced researchers, post-docs and PhD students from several UMONS faculties. The strength of the UMONS Research Institutes lies in the multidisciplinary nature of their teams and the flexibility of their organisation.

At the same time, UMONS recently launched the label "UMONS Innovation Center" which highlights the close collaboration with its associated research centres : MATERIA NOVA, Multitel, Le CLICK, BCRC and C3E2D. With all the spin-offs created in recent years, UMONS is actively involved in the development of its region.

UMONS is active in a wide range of scientific disciplines related to Defence including, but not limited to, materials and production technology, sensors and telecommunication and artificial intelligence.

## HEAD OFFICE

Place du Parc 20  
7000 Mons

## CONTACT PERSON

**Séverine Coppée**  
Technology Transfer Office  
Scientific Advisor

## CONTACT DETAILS

+32 65 37 31 11  
avre@umons.ac.be

**Specific competences:**

UMONS is active in a wide range of other thematics that could be related to Defence, including but not limited to, risk management, human and social sciences, innovative sensors, etc. This is described in the UMONS Research & Innovation brochure, which is available on the website : <https://web.umons.ac.be/en/missions/research/>



Founded in 1831, the University of Namur today has more than 7300 students of 75 different nationalities, nearly 1300 staff members, more than 900 researchers and a R&D budget of 21,4 M€.

It aims to develop quality projects and is involved in multiple research networks, often interdisciplinary, at the local, regional, federal, European and international levels. Its research aims above all at excellence and maintains the necessary balance between fundamental and oriented research. It excels in niche sectors such as in health sciences, sciences and technologies and human sciences.

The research landscape includes 11 transdisciplinary research institutes, and 10 technological platforms combining state-of-the-art scientific equipment, technical knowhow and recognized expertise, accessible to the scientific community as well as to companies. The results of research have led to the filing of numerous patents, technology transfers to industry and the creation of 22 spin-offs.

## HEAD OFFICE

Rue de Bruxelles 61  
5000 Namur

## CONTACT PERSON

**Philippe Degée**  
Scientific Advisor  
Materials & Energy

**Jérôme Mallargé**  
ICT Scientific Advisor

## CONTACT DETAILS

+32 81 72 53 52  
philippe.degee@unamur.be

+32 81 72 50 48  
jerome.mallarge@unamur.be

## Specific competences:

Health, antimicrobial resistance, human-machine interface, AI, security and privacy, Technology, Ethics & Society, Cybersecurity.



The von Karman Institute for Fluid Dynamics (VKI) is an education and research organisation specialized in Fluid Dynamics, in the areas of Aeronautics & Space, Environmental & Industrial Flows, and Turbomachinery & Propulsion. VKI was founded in 1956 with postgraduate education to keep expertise in high speed aerodynamics in NATO countries at the highest level.

For aeronautics, VKI specializes in aero-propulsion by means of turbomachinery, with advanced aero-thermal research on both compressor and turbine side. VKI also performs research to improve the lift of aircraft wings and the aerodynamic and aero-acoustic performance of multirotor vehicles. For space, VKI focuses on atmospheric re-entry flows and thermal protection systems. VKI is also active in cryogenic propellant management for hydrogen powered aircraft and space launchers, and is pioneering in distributed electrical propulsion.

VKI has unique expertise in hypersonics. VKI operates more than 50 testing facilities and wind tunnels, which allows VKI to study complex flows with speeds up to mach 14. The experimental research is combined with world class expertise in numerical modeling and CFD.

## HEAD OFFICE

Chaussée de Waterloo 72  
1640 Rhode-Saint-Genèse

## CONTACT PERSON

**Peter Simkens**  
Executive Director  
Strategy & Partnerships

Philippe Planquart  
Chief Project Management Officer

## CONTACT DETAILS

+32 498 101 354  
peter.simkens@vki.ac.be

+32 2 359 9677  
philippe.planquart@vki.ac.be

# Walloon Defence Actors

Key Stakeholders



## KEY STAKEHOLDERS

# Pôle MecaTech

SECTORS



## KEY STAKEHOLDERS

# Skywin

SECTORS



Pôle MecaTech, Wallonia's competitiveness cluster for the engineering industry, is strengthening its involvement in the Defence sector in line with European sovereignty strategies, national and regional reindustrialization objectives.

### HEAD OFFICE

Business Village Ecolys  
Avenue d'Ecolys 2 bte 33  
5020 Suarlée

### CONTACT PERSON

**Matthieu Janssens**  
Defense Ecosystem Manager

### CONTACT DETAILS

+32 81 20 68 50  
matthieu.janssens@polemecatech.be

Rooted in its four core technological domains—Advanced Manufacturing, Materials & Surfaces, Mechatronics, and Digital Technologies—MecaTech supports innovation that serves both civilian and Defence applications. The cluster facilitates collaborative Defence initiatives by driving specific innovative programs, like CAP4LAND, a structuring national program in the land domain (see cap4land.be), identifying funding opportunities (EDF, EDA, national, regional calls) and guiding stakeholders through project development. It also fosters a dynamic “Defence & Security” ecosystem by mapping national and regional capabilities, promoting synergies, and organizing sector-specific events.

Several projects are already underway in cyber resilience, robotics, and advanced materials, developed in collaboration with major Defence actors and the Belgian Defence. By reinforcing industrial capacities and accelerating the adoption of strategic technologies, MecaTech positions Wallonia's companies as reliable partners in Europe's evolving Defence landscape-ready to meet the technological and operational needs of tomorrow.



### HEAD OFFICE

Avenue d'Ecolys 2 Bte 47  
5020 Suarlée

### CONTACT PERSON

**Agnès Grandjean**  
Deputy Managing Director:  
International

### CONTACT DETAILS

info@skywin.be

Skywin is the aerospace competitiveness cluster of Wallonia. It is an association gathering large and small companies, research organisations and training centres engaged in public-private partnerships and in the implementation of innovative collaborative projects.

Skywin's mission is to sustain and strengthen both technological progress and operational excellence in order to meet the global challenges of the Walloon aerospace industry by developing knowledge, employment and competitiveness for all current and future players in the ecosystem of the aerospace industry in Wallonia. The cluster covers the aeronautics, space and drone sectors but also the defence sector.

The Walloon defence sector still growing constitutes an ecosystem and a strong industrial activity in Wallonia, with several large companies (Belgian and international) developing, producing and marketing their own products (complete control of the value chain) and a significant local supply chain based on SMEs that are constantly developing new skills.

Skywin supports this sector in collaboration with Mecatech, which focuses its efforts on land defence, while Skywin focuses on air defence.

# Agoria Wallonie

SECTORS



## HEAD OFFICE

Rue Ravensteinstraat, 4  
1000 Bruxelles

## CONTACT PERSON

**Valérie Debois**  
Senior Expert Innovation  
Ecosystems

## CONTACT DETAILS

valerie.debois@agoria.be

Agoria Wallonie, in close cooperation with Agoria-BSDI, supports its Defence sector members through strategic guidance, privileged access to decision-makers and insight into emerging industrial needs.

Agoria Wallonie actively represents Walloon companies to regional and federal (through Agoria-BSDI) authorities, helping advance key dossiers linked to strategic sovereignty. In its dialogue with the Walloon Government, Agoria Wallonie supports regulatory simplification (e.g., export licences) and helps companies access federal instruments.

Agoria Wallonie and Agoria-BSDI also support Defence and dual-use SME subcontractors by promoting their solutions and enabling cooperation across the Belgian Defence ecosystem - including Belgian Defence and other armed services - and key Walloon and Belgian stakeholders (primes and SMEs, research and higher-education institutions, public authorities, ...).

Sector visibility is strengthened through strategic events and targeted surveys reflecting companies' concrete needs.

# AWEX

SECTORS



## HEAD OFFICE

Pl. Saintelette 2  
1080 Bruxelles

## CONTACT PERSON

**Rafael Jaimes Contreras**  
Aerospace & Defence Industry  
Business Developer

## CONTACT DETAILS

+32 2 421 82 11  
defense@awex.be

The Wallonia Export & Investment Agency (AWEX) is your gateway to southern Belgium's agile and innovation-driven defence and security ecosystem.

We support Walloon SMEs and major players in the export of dual-use and military technologies from advanced materials and land systems to secure IT, drones, and space-based services. AWEX provides market intelligence, regulatory guidance, and targeted matchmaking with OEMs, NATO agencies, and EU programmes. We coordinate collective pavilions at leading international defence and security trade shows and organise specialised B2B missions to key procurement hubs worldwide.

For foreign contractors, we identify qualified suppliers, facilitates industrial partnerships, supports offset compliance, and promote investments in Wallonia's aerospace, cyber-security, and additive manufacturing clusters.

Rely on AWEX to accelerate partnerships, strengthen supply chains, and turn breakthrough ideas into operational capability.

## Giwias

SECTORS



## Ignity

SECTORS



## GIWAS

**GIWAS – the Walloon Aerospace and Space Industries Group – is the federation that brings together and represents the key players of the aerospace and space sector in Wallonia.**

Its mission is to position Wallonia as an internationally recognised aerospace hub by promoting technological excellence, research and innovation, and economic attractiveness, serving civil society while addressing defence and sovereignty challenges.

GIWAS brings together over 80 companies and organisations across the entire value chain, representing more than 11,000 highly skilled jobs and generating an annual turnover exceeding €3.5 billion.

The federation represents and defends sector interests with public authorities, fosters cooperation between industrial, academic, scientific and institutional stakeholders, and enhances the industry's attractiveness for talent, strategic projects and investment. Its actions are structured around five thematic working groups: space, aeronautics, research, SMEs and defence, which unite experts to drive concrete initiatives and deliver high-impact recommendations.

GIWAS positions itself as a dual-use aerospace actor, promoting the development of critical civil technologies designed to be robust, secure and fully compatible with defence, security and sovereignty requirements.

## HEAD OFFICE

Avenue d'Ecolys 2/47  
5020 Namur

## CONTACT PERSON

**Agnes FLEMAL**  
COO

## CONTACT DETAILS

+32 494 466 304  
info@giwas.be

## IGNITY

**IGNITY is the leading deep tech accelerator in Wallonia, Belgium, with a strong focus on dual-use innovation in the Defence sector.**

With over 25 years of experience supporting high-tech startups, IGNITY has developed a unique methodology leveraging proprietary tools such as MatMax™, FinMax™, and its TRL/CRL Boosters to fast-track both technological and commercial readiness.

As a key player in European Defence innovation, IGNITY operates the Belgian site of NATO's DIANA accelerator, leads the MaJoR program under the European Defence Fund (EDF) focused on the maintenance and repair of military platforms, and is a strategic partner in the EUDIS BAMB initiative (Business Accelerator and Matchmaking Mechanism). IGNITY holds a unique position at the crossroads of NATO and EU innovation ecosystems, providing privileged access to a vast global network of testing centers, investors, industry leaders, and allied innovation hubs.

Through tailored coaching, market validation, and international matchmaking, IGNITY plays a pivotal role in shaping a new generation of dual-use startups, contributing to Europe's technological sovereignty, operational readiness, and transatlantic cooperation.

## HEAD OFFICE

Rue du Bois Saint-Jean 15/1  
4102 Seraing

## CONTACT PERSON

**Sandrine Legrand**  
Administrative Manager  
Manager Assistant

## CONTACT DETAILS

+32 4 367 30 63  
info@ignity.be

## KEY STAKEHOLDERS

# NCP Wallonie

SECTORS



### HEAD OFFICE

Courbevoie 13 (Silersquare)  
1348 Louvain-la-Neuve

### CONTACT PERSON

**Francisco Santana Ferra**  
Coordinator & manager

### CONTACT DETAILS

+32 472 17 29 96  
francisco.santana.ferra@ncpwallonie.be

**NCP Wallonie is the regional contact point for the Horizon Europe programme in Wallonia, Belgium.**

It is part of the national network of NCPs (National Contact Points) and supports Walloon stakeholders—companies, research centres, universities, and public bodies—in accessing European R&D funding (Horizon Europe, European Defence Fund...).

Its core services include: Providing tailored advice on EU funding opportunities | Supporting project proposal preparation | Facilitating partnerships at European level.

NCP Wallonie can be a strategic enabler for the defence sector by bridging regional capabilities with European funding and partnerships. Its ability to guide stakeholders through the complex EU funding landscape makes it well-positioned to boost Wallonia's contribution to Europe's defence innovation ecosystem.

## KEY STAKEHOLDERS

# SPW EER

SECTORS



### HEAD OFFICE

Boulevard Cauchy 43-45  
5000 Namur

### CONTACT DETAILS

+32 81 77 82 11

**The SPW Economy, Employment, and Research (SPW EER) is the Walloon Government's administration in charge of implementing regional policies in economy, employment, and research. It represents Wallonia at various levels of governance and serves as a bridge to European programs.**

As a central player in fostering business growth, quality employment, and innovation, SPW EER provides financial support to enterprises, regulates economic development, ensures compliance with legal frameworks, and advises the government on socio-economic strategies. It also coordinates major initiatives such as competitiveness clusters and manages EU co-funded aid programs.

- In the economy sector, it supports companies through investment grants, business vouchers, and the development of economic zones. It promotes the social economy, regulates commercial activities, and manages licensing for the import, export, and transit of arms and dual-use goods.
- In the employment sector, it encourages job creation, professional integration, vocational training, and the digital transition of schools. It also issues work permits and professional cards to non-EU nationals.
- In the research and innovation sector, it funds, evaluates, and promotes applied research projects involving companies, universities, and research centers, while fostering scientific awareness among youth and the public.

Within SPW EER, the Arms Licensing Directorate is specifically responsible for managing licenses for the import, export, transit, and transfer of arms, ammunition, military-use equipment, and associated technologies. Created following the 2003 regionalization of these competences, the Directorate also handles applications for dual-use goods and technologies, and represents Wallonia in relevant European and international meetings.

# Wallonie Entrepreneure

SECTORS



## **WE** Wallonie Entrepreneure

### HEAD OFFICE

Avenue Maurice Destenay 13  
4000 Liège

### CONTACT PERSON

**Sarah Krins**  
Investment Manager

### CONTACT DETAILS

sarah.krins@wallonie-entrepreneure.be

Wallonie Entrepreneure (WE) is Wallonia's key economic and financial partner for high-potential companies. WE provides equity investments, guarantees, and loans to support businesses at every critical stage of their development.

Its mission is to create long-term value in Wallonia by fostering sustainable employment, strengthening industrial and energy sovereignty, lowering carbon emissions, and accelerating innovation and R&D transformation. WE manages a portfolio worth over €4,6 billion, with stakes in leading defence-related companies such as FN Browning and New Lachaussée, as well as dual-use, aerospace, and space industry players like Sonaca, Safran Aero Boosters, and Aerospacelab. It also supports a network of over 60 defence subcontractors and partners with FNX Ventures, a fund dedicated to startups in cybersecurity, AI, security, detection, and other defence-adjacent technologies.

WE operates through three main financial levers:

- Equity capital, acting as a patient minority shareholder;
- Loans, supporting both tangible and intangible investments, as well as working capital needs;
- Guarantees, facilitating access to credit and international expansion.

In all its actions, WE promotes public-private co-financing, supports scale-up as well as ramp-up needs, and provides strategic guidance for participation in European programmes such as EDF, NIF, and EDIP.



# Companies

		AIR	LAND	SEA	SPACE		UNMANNED INTELLIGENT AUTONOMOUS SYSTEMS (UIAS)	INFO. PROCESSING DATA MANAGEMENT COMMUNICATION EMB. INTELLIGENT SYSTEMS	MUNITION, EFFECTORS & INTEGRATION)	MATERIALS & STRUCTURES	LIFE CYCLE SUPPORT & SERVICES	OTHER SPECIFIC COMPETENCE (SEE COMPANY PAGE)
ACIC	SME							<input checked="" type="checkbox"/>				<input checked="" type="checkbox"/>
ADVANCED COATINGS	SME											<input checked="" type="checkbox"/>
AEROSPACE LAB	LC											
AGINTECH	SME											<input checked="" type="checkbox"/>
ALKAR TECHNOLOGY	SME									<input checked="" type="checkbox"/>		
ALTÉRIS TECHNOLOGIES	SME						<input checked="" type="checkbox"/>	<input checked="" type="checkbox"/>	<input checked="" type="checkbox"/>		<input checked="" type="checkbox"/>	<input checked="" type="checkbox"/>
AMOS	LC							<input checked="" type="checkbox"/>				<input checked="" type="checkbox"/>
ANY-SHAPE	SME											<input checked="" type="checkbox"/>
BALTEAU NDT	SME											<input checked="" type="checkbox"/>
BASE DE BARONVILLE	SME								<input checked="" type="checkbox"/>	<input checked="" type="checkbox"/>		<input checked="" type="checkbox"/>
BEBLUE CRYOTECH S.A.	SME						<input checked="" type="checkbox"/>			<input checked="" type="checkbox"/>		
BECOVER	LC							<input checked="" type="checkbox"/>			<input checked="" type="checkbox"/>	<input checked="" type="checkbox"/>
BLINQY	SME							<input checked="" type="checkbox"/>			<input checked="" type="checkbox"/>	<input checked="" type="checkbox"/>
BREUER TECHNICAL DEVELOPMENT (BTD)	SME											<input checked="" type="checkbox"/>
BSOLUTIONS	SME									<input checked="" type="checkbox"/>	<input checked="" type="checkbox"/>	<input checked="" type="checkbox"/>
CALYOS	SME									<input checked="" type="checkbox"/>		<input checked="" type="checkbox"/>
CAPPAUL	SME									<input checked="" type="checkbox"/>		
CARAT DUCHATELET	LC											
CASTINGPAR	SME									<input checked="" type="checkbox"/>		

# Companies

		AIR	LAND	SEA	SPACE		UNMANNED INTELLIGENT AUTONOMOUS SYSTEMS (UIAS)	INFO. PROCESSING DATA MANAGEMENT COMMUNICATION EMB. INTELLIGENT SYSTEMS	MUNITION, EFFECTORS & INTEGRATION)	MATERIALS & STRUCTURES	LIFE CYCLE SUPPORT & SERVICES	OTHER SPECIFIC COMPETENCE (SEE COMPANY PAGE)
CILYX ENGINEERING	SME											
COEXPAIR	SME											
CONSTELLR	SME											
CPP	LC											
DARDENNE	SME											
DECUBE GROUP	LC											
DEFENSEWISE	SME											
DEKIMO	LC											
DELTATEC	SME											
DUMOULIN AERO	LC											
DYNALI	SME											
ELIOSYS	SME											
EURENCO CLERMONT	LC											
EHP (EURO HEAT PIPES SA)	SME											
EURESYS	SME											
EUROPEAN METROLOGY SYSTEMS (EMS)	SME											
EXAIL	SME											
SUB-ALLIANCE / FERONYL	SME											
FILAME	SME											

# Companies

		AIR	LAND	SEA	SPACE		UNMANNED INTELLIGENT AUTONOMOUS SYSTEMS (UIAS)	INFO. PROCESSING DATA MANAGEMENT COMMUNICATION EMB. INTELLIGENT SYSTEMS	MUNITION, EFFECTORS & INTEGRATION)	MATERIALS & STRUCTURES	LIFE CYCLE SUPPORT & SERVICES	OTHER SPECIFIC COMPETENCE (SEE COMPANY PAGE)
FN BROWNING GROUP	LC								<input checked="" type="checkbox"/>			
GD TECH	SME						<input checked="" type="checkbox"/>	<input checked="" type="checkbox"/>	<input checked="" type="checkbox"/>	<input checked="" type="checkbox"/>		<input checked="" type="checkbox"/>
GENITEK ENGINEERING	SME							<input checked="" type="checkbox"/>			<input checked="" type="checkbox"/>	
GLOBAL MOBILE LAB (GML)	SME											<input checked="" type="checkbox"/>
GROUPEMECA (VANHULEN)	LC								<input checked="" type="checkbox"/>	<input checked="" type="checkbox"/>	<input checked="" type="checkbox"/>	
HEXCEL COMPOSITES	SME									<input checked="" type="checkbox"/>		
HIGH-TECH PLASTICS EUROPE	SME											
ID2MOVE	OTHER						<input checked="" type="checkbox"/>	<input checked="" type="checkbox"/>				TESTING
ID2MOVE	SME						<input checked="" type="checkbox"/>			<input checked="" type="checkbox"/>	<input checked="" type="checkbox"/>	<input checked="" type="checkbox"/>
ICA	SME							<input checked="" type="checkbox"/>	<input checked="" type="checkbox"/>		<input checked="" type="checkbox"/>	<input checked="" type="checkbox"/>
INNOVATIVE COATING SOLUTIONS (ICS)	SME								<input checked="" type="checkbox"/>	<input checked="" type="checkbox"/>		<input checked="" type="checkbox"/>
ISOMATEX	SME									<input checked="" type="checkbox"/>		
IT-OPTICS	SME							<input checked="" type="checkbox"/>		<input checked="" type="checkbox"/>	<input checked="" type="checkbox"/>	
JDC INNOVATION	SME									<input checked="" type="checkbox"/>		
JOHN COCKERILL	LC						<input checked="" type="checkbox"/>	<input checked="" type="checkbox"/>	<input checked="" type="checkbox"/>	<input checked="" type="checkbox"/>	<input checked="" type="checkbox"/>	
KNDS Belgium	LC								<input checked="" type="checkbox"/>			
LAMBDA-X	SME						<input checked="" type="checkbox"/>					
LASEA	SME						<input checked="" type="checkbox"/>		<input checked="" type="checkbox"/>	<input checked="" type="checkbox"/>		
MACHINESIGHT	SME										<input checked="" type="checkbox"/>	<input checked="" type="checkbox"/>

# Companies

		AIR	LAND	SEA	SPACE		UNMANNED INTELLIGENT AUTONOMOUS SYSTEMS (UIAS)	INFO. PROCESSING DATA MANAGEMENT COMMUNICATION EMB. INTELLIGENT SYSTEMS	MUNITION, EFFECTORS & INTEGRATION)	MATERIALS & STRUCTURES	LIFE CYCLE SUPPORT & SERVICES	OTHER SPECIFIC COMPETENCE (SEE COMPANY PAGE)
MEBF	SME								✓	✓		
MECASOFT	SME								✓			
MOCKEL	SME											✓
M3 SYSTEMS BELGIUM	SME						✓					✓
MIRMEX MOTOR	SME						✓		✓			✓
MPP	SME						✓			✓	✓	
MUSTAD	LC								✓	✓		
NANOPYRO	SME								✓	✓		
NEMAND	SME							✓			✓	✓
NSILITION	SME											✓
OPEN ENGINEERING	SME						✓			✓		✓
OPTRION	SME						✓		✓	✓	✓	✓
PATRIA CENTER ENGINE BELGIUM	LC										✓	✓
PIX COATING	SME						✓	✓	✓	✓	✓	✓
PLASTISART	SME									✓		
PTS MACHINING	SME									✓		
Q-SQUARE FORCE	SME										✓	
SABCA	LC									✓	✓	
SABENA ENGINEERING	LC						✓			✓	✓	

# Companies

		AIR	LAND	SEA	SPACE		UNMANNED INTELLIGENT AUTONOMOUS SYSTEMS (UIAS)	INFO. PROCESSING DATA MANAGEMENT COMMUNICATION EMB. INTELLIGENT SYSTEMS	MUNITION, EFFECTORS & INTEGRATION)	MATERIALS & STRUCTURES	LIFE CYCLE SUPPORT & SERVICES	OTHER SPECIFIC COMPETENCE (SEE COMPANY PAGE)
SAFRAN AERO BOOSTER	LC									<input checked="" type="checkbox"/>	<input checked="" type="checkbox"/>	<input checked="" type="checkbox"/>
SAGITA	SME						<input checked="" type="checkbox"/>					
SCOUP-CHP CONSULT	SME						<input checked="" type="checkbox"/>		<input checked="" type="checkbox"/>	<input checked="" type="checkbox"/>	<input checked="" type="checkbox"/>	<input checked="" type="checkbox"/>
SENSY LOAD CELLS	SME						<input checked="" type="checkbox"/>	<input checked="" type="checkbox"/>		<input checked="" type="checkbox"/>	<input checked="" type="checkbox"/>	
SERVIPLAST	SME									<input checked="" type="checkbox"/>		
SHUR-LOK INTERNATIONAL	LC									<input checked="" type="checkbox"/>		<input checked="" type="checkbox"/>
SOBELCOMP	SME									<input checked="" type="checkbox"/>		
SONACA	LC								<input checked="" type="checkbox"/>	<input checked="" type="checkbox"/>	<input checked="" type="checkbox"/>	
SOUDOBEAM	SME									<input checked="" type="checkbox"/>		<input checked="" type="checkbox"/>
SPACEBEL	SME							<input checked="" type="checkbox"/>				
STARION	LC											
TECHNICAL AIRBORNE COMPONENTS (TAC)	SME									<input checked="" type="checkbox"/>		
TELESPAZIO BELGIUM	LC							<input checked="" type="checkbox"/>				
THALES BELGIUM	LC											
V2i	SME						<input checked="" type="checkbox"/>	<input checked="" type="checkbox"/>	<input checked="" type="checkbox"/>	<input checked="" type="checkbox"/>	<input checked="" type="checkbox"/>	
X-RIS	SME						<input checked="" type="checkbox"/>		<input checked="" type="checkbox"/>	<input checked="" type="checkbox"/>	<input checked="" type="checkbox"/>	<input checked="" type="checkbox"/>

# Research Centers & Universities

		AIR	LAND	SEA	SPACE		UNMANNED INTELLIGENT AUTONOMOUS SYSTEMS (UIAS)	INFO. PROCESSING DATA MANAGEMENT COMMUNICATION EMB. INTELLIGENT SYSTEMS	MUNITION, EFFECTORS & INTEGRATION)	MATERIALS & STRUCTURES	LIFE CYCLE SUPPORT & SERVICES	OTHER SPECIFIC COMPETENCE (SEE COMPANY PAGE)
CENAERO	RC									<input checked="" type="checkbox"/>		<input checked="" type="checkbox"/>
CENTEXBEL	RC									<input checked="" type="checkbox"/>		<input checked="" type="checkbox"/>
CETIC	RC						<input checked="" type="checkbox"/>	<input checked="" type="checkbox"/>			<input checked="" type="checkbox"/>	
CRM GROUP	RC							<input checked="" type="checkbox"/>	<input checked="" type="checkbox"/>	<input checked="" type="checkbox"/>		<input checked="" type="checkbox"/>
CSL (CENTRE SPATIAL DE LIÈGE)	RC							<input checked="" type="checkbox"/>	<input checked="" type="checkbox"/>	<input checked="" type="checkbox"/>		<input checked="" type="checkbox"/>
ERM	UNIV						<input checked="" type="checkbox"/>	<input checked="" type="checkbox"/>	<input checked="" type="checkbox"/>	<input checked="" type="checkbox"/>		<input checked="" type="checkbox"/>
JRI4SPACE	OTHER							<input checked="" type="checkbox"/>		<input checked="" type="checkbox"/>	<input checked="" type="checkbox"/>	<input checked="" type="checkbox"/>
MULTITEL	RC						<input checked="" type="checkbox"/>	<input checked="" type="checkbox"/>		<input checked="" type="checkbox"/>		<input checked="" type="checkbox"/>
SIRRIS	RC						<input checked="" type="checkbox"/>	<input checked="" type="checkbox"/>	<input checked="" type="checkbox"/>	<input checked="" type="checkbox"/>	<input checked="" type="checkbox"/>	
SYNHERA	UNIV						<input checked="" type="checkbox"/>	<input checked="" type="checkbox"/>		<input checked="" type="checkbox"/>	<input checked="" type="checkbox"/>	<input checked="" type="checkbox"/>
UCLOUVAIN	UNIV						<input checked="" type="checkbox"/>	<input checked="" type="checkbox"/>		<input checked="" type="checkbox"/>	<input checked="" type="checkbox"/>	<input checked="" type="checkbox"/>
ULB	UNIV						<input checked="" type="checkbox"/>	<input checked="" type="checkbox"/>		<input checked="" type="checkbox"/>	<input checked="" type="checkbox"/>	
ULIÈGE	UNIV						<input checked="" type="checkbox"/>	<input checked="" type="checkbox"/>	<input checked="" type="checkbox"/>	<input checked="" type="checkbox"/>	<input checked="" type="checkbox"/>	<input checked="" type="checkbox"/>
UMONS	UNIV						<input checked="" type="checkbox"/>	<input checked="" type="checkbox"/>		<input checked="" type="checkbox"/>		<input checked="" type="checkbox"/>
UNAMUR	UNIV						<input checked="" type="checkbox"/>	<input checked="" type="checkbox"/>		<input checked="" type="checkbox"/>		<input checked="" type="checkbox"/>
VKI-VON KARMAN INSTITUTE	RC						<input checked="" type="checkbox"/>					<input checked="" type="checkbox"/>

# Key Stakeholders

		AIR	LAND	SEA	SPACE		UNMANNED INTELLIGENT AUTONOMOUS SYSTEMS (UIAS)	INFO. PROCESSING DATA MANAGEMENT COMMUNICATION EMB. INTELLIGENT SYSTEMS	MUNITION, EFFECTORS & INTEGRATION)	MATERIALS & STRUCTURES	LIFE CYCLE SUPPORT & SERVICES	OTHER SPECIFIC COMPETENCE (SEE COMPANY PAGE)
PÔLE MECATECH	KEY STAKEHOLDERS						✓	✓	✓	✓	✓	✓
SKYWIN	KEY STAKEHOLDERS						✓	✓		✓	✓	✓
AGORIA WALLONIE	KEY STAKEHOLDERS						✓	✓	✓	✓	✓	
AWEX	KEY STAKEHOLDERS						✓	✓	✓	✓	✓	
GIWAS	KEY STAKEHOLDERS											
IGNITY	KEY STAKEHOLDERS						✓	✓	✓	✓	✓	
NCP WALLONIE	KEY STAKEHOLDERS						✓	✓	✓	✓	✓	✓
SPW EER	KEY STAKEHOLDERS						✓	✓	✓	✓	✓	
WALLONIE ENTREPRENDRE	KEY STAKEHOLDERS						✓	✓	✓	✓	✓	





[polemecatech.be](http://polemecatech.be)

**Anthony Van Putte,**  
General Manager  
[anthony.vanputte@polemecatech.be](mailto:anthony.vanputte@polemecatech.be)

**Matthieu Janssens**  
Defence Ecosystem Manager  
[matthieu.janssens@polemecatech.be](mailto:matthieu.janssens@polemecatech.be)



[skywin.be](http://skywin.be)

**Etienne Pourbaix**  
General Manager  
[etienne.pourbaix@skywin.be](mailto:etienne.pourbaix@skywin.be)

**Agnès Grandjean**  
International Relations & Defence  
[agnes.grandjean@skywin.be](mailto:agnes.grandjean@skywin.be)



PHOTO CREDITS

